

March 2008

Description

The universal SPA² Programmable Limit Alarm Trips provide on/off control, warn of unwanted process conditions, alarm on rate-of-change and provide emergency shutdown. Very versatile, they accept a signal input from transmitters, temperature sensors and a wide array of other monitoring and control instruments:

- **Current and Voltage Signals**
- **23 RTD Types**
- **9 Thermocouple Types**
- **Resistance and Potentiometer Devices**
- **Direct Millivolt Sources**

Dual and Quad Alarm Trip Outputs

The 4-wire (line/mains-powered) SPA² provides two or four independent and individually-configurable alarm relay outputs when a monitored process variable falls outside of user-set high and/or low limits. This is typically used to activate a warning light, annunciator, bell, pump, motor or shutdown system.

Figure 1. Available SPA² models deliver versatile and programmable input and output choices.

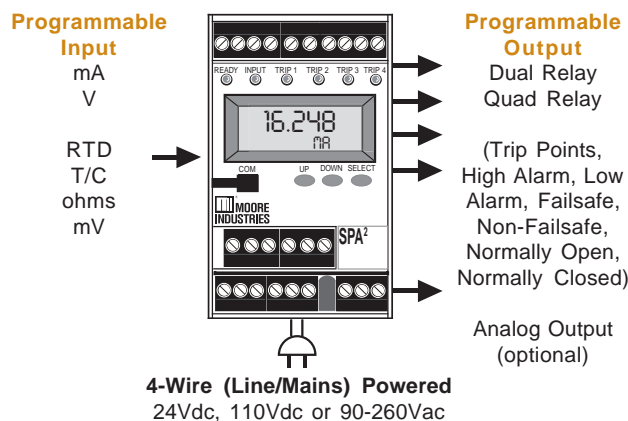

The SPA² features a metal, RFI resistant housing with display that snaps onto standard DIN-style rails.

Features

- **Universal plant standard.** There's no need to stock dozens of different fixed range alarm trips.
- **20-bit input resolution.** Delivers industry-best digital accuracy for both sensor (RTD and thermocouple) and analog (current/voltage) inputs.
- **Site- and PC-Programmable.** Featuring security password protection, the SPA² offers the choice of using front panel pushbuttons or our Windows®-based Intelligent PC Configuration Software for fast and simple set up.
- **Long-term stability.** Provides up to 5 years between scheduled calibrations.
- **Large 5-digit process and status readout.** A display shows menu prompts during pushbutton configuration and, when the SPA² is in operation, shows the process variable, the output or toggles between the two in selectable engineering units.
- **Combined alarm trip and transmitter.** The analog output (-AO) option reduces costs and installation time when both alarm and transmitter functions are needed at the same location.
- **Isolated and RFI/EMI protection.** Delivers superior protection against the effects of ground loops, and plant noise, radio frequency and electromagnetic interference.

Certifications



Factory Mutual – FM Approvals – cFMus (US/Canada), Non-Incendive – Class I, Division 2, Groups A, B, C, D
Suitable for use in General Locations and Hazardous 'Classified' Locations when mounted in suitable protective enclosures



CE Conformant – EMC Directive 89/336/EEC EN 61326; Low Voltage Directive 73/23/EEC EN 61010

SPA²

Programmable Current/Voltage
and RTD/Thermocouple Limit Alarm Trips

Site- and PC-Programmable

Operating parameters configure quickly and easily using front panel pushbuttons or our Intelligent PC Configuration Software. Programmable functions include:

- Security password protection on/off and password
- Input type and measurement range (zero and full scale values)
- Input and output trimming
- High or low alarm(s) with trip points
- Failsafe or non-failsafe, and normally open or normally closed alarm relays
- Alarm deadband (0-100%) and alarm time delay
- T/C reference junction compensation (on/off)
- Display parameters (scale, engineering units, and set number of digits after the decimal point)
- Differential or averaging of RTD inputs
- Standard and custom linearization curves (up to 128 points)*
- Analog output range**
- On input failure, upscale or downscale drive, fail to last value or fail to selected value**
- Analog signal output damping (0-30 seconds)**

*Programmable via the PC Configuration Software only.

**Models with Analog Output (-AO) option.

Powers a 2-Wire Transmitter

The SPA² (HLPRG: current/voltage input model) comes standard with 2-wire transmitter excitation that provides 24Vdc to power the loop. This saves the cost of specifying and installing an additional instrument power supply to power a 2-wire transmitter on the input loop.

Figure 2. The SPA² provides transmitter excitation to power a 2-wire transmitter.

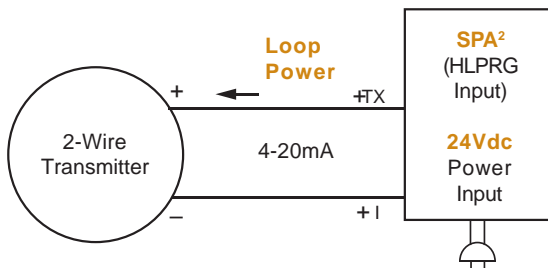
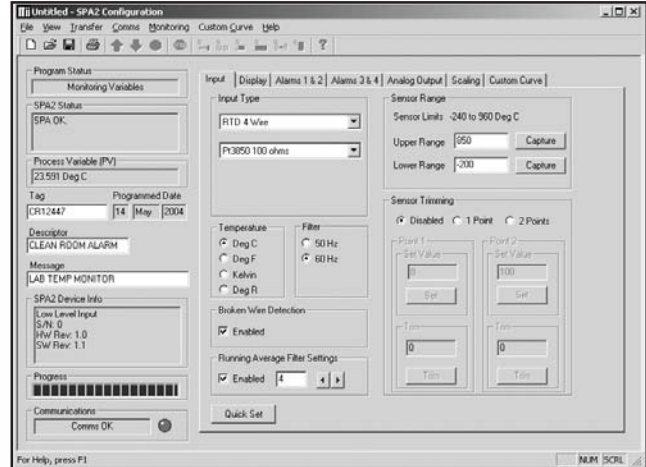

Figure 3. In addition to pushbutton configuration, the SPA² programs quickly from a single software window.



Versatile Alarm Options

Each individually-configurable SPA² alarm trip relay programs via the PC software as a:

High or Low Limit Process Alarm—Monitor a temperature, pressure, level, flow, position or status variable, and use to warn of unwanted process conditions (Figure 4), provide emergency shutdown or provide on/off control (Figure 5).

Rate-of-Change Alarm—Monitor an input for a change in value with respect to time (Figure 6). The alarm trips when the input rate-of-change exceeds a user-selected rate (Delta) over a user selected time period (Delta Time).

Input Fault Alarm—Setting one of the alarm's relays to trip on input or self-diagnostic failure (without affecting the other relay being used to monitor the process) is typically implemented to warn of a failure, such as a broken sensor, without tripping more critical process alarms or shutting down the process.

Out of Range Alarm—Monitor your process variable (PV). If the value strays past user-set limits, the SPA² will go into an alarm state indicating that the PV has gone out of the allowed range.

Self-Diagnostic Alarm—The SPA² checks its own operation and configuration upon start up, and then continuously monitors its status during operation. One of the SPA²'s relays can be configured to trip if it senses that it is not operating properly.

Quick Ranging Calibration

Using the front panel pushbuttons or the PC Configuration Software (instead of potentiometers which can drift), precise zero and span settings can be made in seconds. Just select the zero and span values, and the push of a button locks the values into the alarm trip's memory.

Figure 4. High and/or low limit alarms, with a selectable deadband to reduce false alarms, can be used to warn of unwanted process conditions or to provide emergency shutdown.

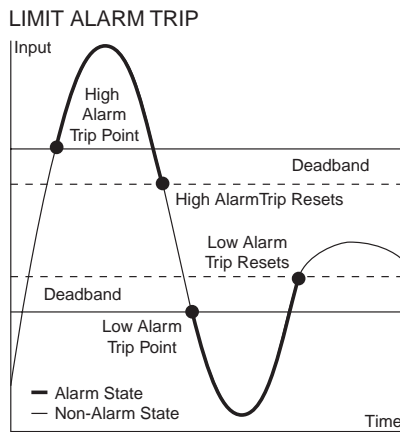

Figure 5. The SPA² can be used as a simple on/off controller such as those required in level applications (pump/valve control) when filling or emptying a container or tank.

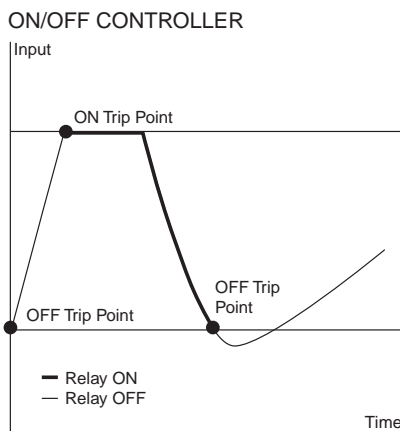
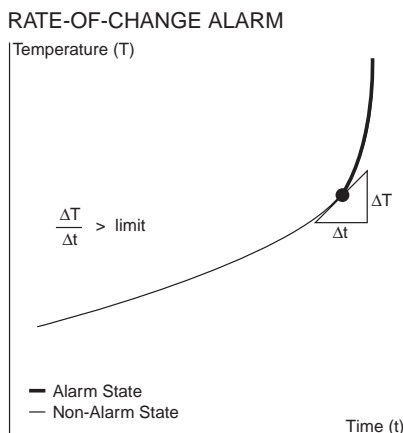

Figure 6. The SPA² can be set to trip when the input rate-of-change exceeds a user-selected rate (Delta) over a user-selected time period (Delta Time).



Combination Alarm and Isolated Transmitter

When ordered with the Analog Output (-AO) option, the SPA² provides a proportional and isolated analog retransmission of the input signal that can be sent to remote monitoring/control devices like a DCS, PLC, PC, indicator or data recorder (Figure 7). All analog parameters can be selected using the SPA² pushbuttons or the Intelligent PC Configuration Software. Upon input failure, the analog output can be user-set for upscale or downscale drive or fail to last value.

Figure 7. When ordered with the Analog Output (-AO) option, the SPA² is a combination alarm trip and signal transmitter.

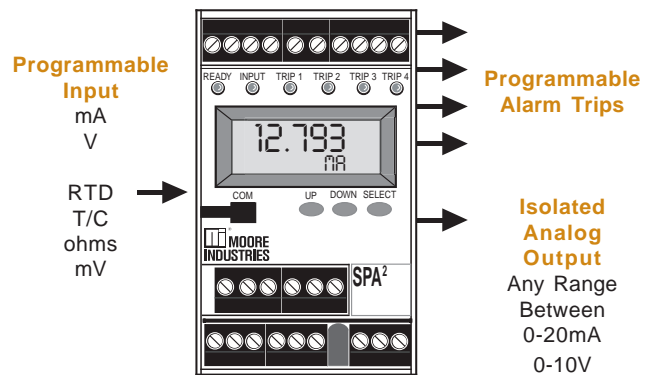

Superior Reference Junction Compensation

Uncompensated plastic terminals are very susceptible to ambient temperature changes that may result in readings that are "off" by several degrees. SPA² models that accept temperature inputs (TPRG input) feature metal terminals and advanced electronic compensation techniques that provide a stable measurement in fluctuating ambient temperature conditions.

Continuous Self-Diagnostics

Incorporating advanced self-diagnostics, the SPA² checks its own operation and configuration upon start up and then continuously monitors its status during operation. If it senses that it is not operating properly, it displays an error message on its display indicating what condition has occurred. In addition, one or more of the alarm trip outputs can be set as a fault alarm which will trip when an unwanted diagnostic condition occurs.

SPA²

Programmable Current/Voltage
and RTD/Thermocouple Limit Alarm Trips

Custom 128-Point Linearization Curves

The ability to plot a custom linearization curve is beneficial when non-linear input signals must be converted to linear output representations (Figure 8). Typical applications include monitoring a non-linear transducer, the level of odd-shaped tanks and flow meter linearization.

Figure 8. Using the Intelligent PC Configuration Software, up to 128 custom linearization points can be selected and saved in the SPA²'s memory to compensate for non-linear input signals.

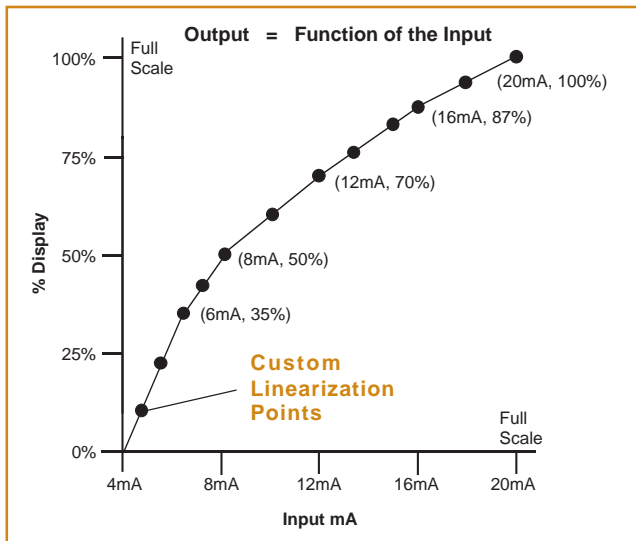

Total Sensor Diagnostics for RTD Inputs

Our SPA² Programmable Limit Alarm Trip (TPRG input model) performs continuous sensor diagnostics (Figure 10). This industry-first and patented Moore Industries feature saves you time and money by letting you know when a problem occurs, and its type and location. If the RTD input breaks, the user can decide whether or not to trip one or more alarms to indicate trouble. A plain-English error message on the display, as well as on the PC Configuration Software, indicates exactly which RTD wire has broken. Specific error messages eliminate the work of removing the sensor or checking all lead wires to diagnose a problem. If equipped with the Analog Output (-AO) option, the user has the option of driving the analog output either upscale or downscale on sensor failure.

Trim to Specific Curve Segments

The SPA² can be trimmed with two data points within the selected zero and span measurement range (Figure 9). This allows a complete process range to be monitored while placing measurement emphasis on a critical segment of the range. This provides incredible precision over a limited portion of the span while measuring the remainder of the span with outstanding accuracy.

Figure 9. The SPA² can be set to measure the segment most critical to the process.

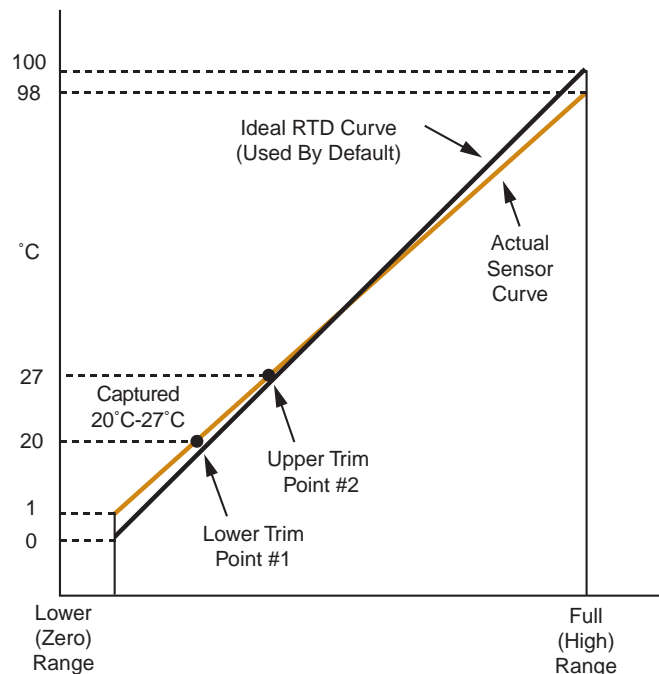
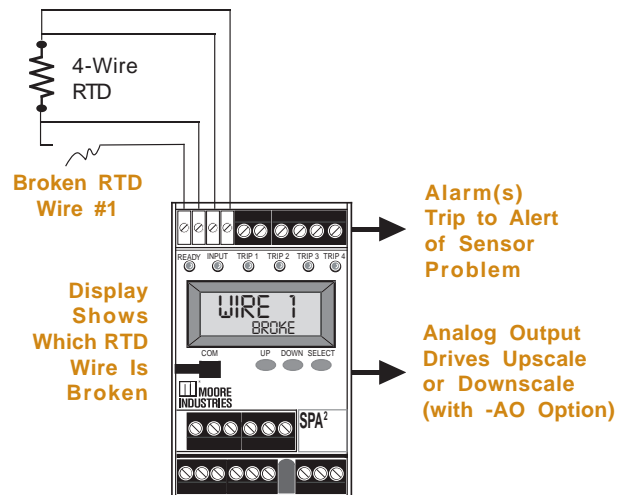

Figure 10. Patented "Total Sensor Diagnostics" saves troubleshooting time by identifying which sensor wire has broken.



Specifications (HLPRG: mA and V Input Model)

Performance Alarm Trip Repeatability: Current inputs, ± 2 microamps (0.01% of 20mA span); Voltage inputs, ± 1 mV (0.01% of maximum span)
Display Accuracy: ± 1 digit; when scaling the display (or in Custom Mode), high input-to-display span ratios decrease display accuracy
Input Accuracy: Current inputs, ± 2 microamps (0.01% of 20mA span); Voltage inputs, ± 1 mV (0.01% of maximum span)
Stability: Refer to Table 1
Dead Band: 11.5V or 50mA, maximum in Linear Mode; equivalent of maximum input range in user-set engineering units in Scaling/Custom Mode
Response Time: 256msec maximum (Defined as the time from step change on input to alarm state change when alarm is set to trip mid-point)
Alarm Trip Delay: Programmable from 0-120 seconds
Line Voltage Effect: $\pm 0.002\%$ of span for a 1% change in line voltage (AC or DC)
Isolation: 1000Vrms between case, input, output (units with -AO option) and power, continuous. Will withstand a 1200Vac dielectric strength test for one minute (with no breakdown)
WITH -RF OPTION: 500Vrms between case, input, output and power
Power Supply: 24DC range, 18-30Vdc; UAC range, 90-260Vac; 110DC range, 75-150Vdc
Power Consumption: 3.5W maximum (24DC

Performance (continued) supply); 4W maximum (UAC supply); 6W maximum (110DC supply)
Input Impedance: Current inputs, 20 ohms; Voltage inputs, 1 Mohm
Input Over-Range Protection: Voltage inputs, ± 30 Vdc; Current inputs, ± 100 mA
TX Power Supply: 24Vdc, $\pm 10\%$ @24mA (regulated)

Performance WITH ANALOG OUTPUT with Analog Output Accuracy: Current, $\pm 0.01\%$ of maximum span (± 2 microamps); Voltage, $\pm 0.01\%$ of maximum span (± 1 mV)
Response Time: 256msec maximum (128msec typical) for the output to change from 10% to 90% of its scale for an input step change of 0 to 100%
Ripple (up to 120Hz): Current output, 10mVp-p when measured across a 250 ohm resistor; Voltage output, 50mVp-p maximum
Output Limiting: Current outputs,

Output	Failure Limits
0-20mA	0, 23.6mA
4-20mA	3.6, 23.6mA
X-20mA (90% of X)	23.6mA

Voltage output, -0.5-11V
Load Effect (current outputs): $\pm 0.01\%$ of span from 0 to 1000 ohms resistance on current output

Ambient Operating Range: -40°C to +85°C (-40°F to +185°F)
Relay Range: -25°C to +70°C (-13°F to +158°F)
Storage Range: -40°C to +85°C (-40°F to +185°F)
Ambient Temperature Effect: Current, 2 microamps/°C; Voltage,

Ambient Conditions (continued) 1mV/°C; Output, $\pm 0.009\%$ of maximum span/°C
Relative Humidity: 0-95%, non-condensing
RFI/EMI Protection: 10V/m@80-1000MHz, 1kHz AM, when tested to IEC61326 with 0.5% of span or less error
WITH -RF OPTION: 20V/m@80-1000MHz, 1kHz AM, when tested to IEC61326 with 0.5% of span or less error
Noise Rejection: Common Mode, 100dB@50/60Hz Normal Mode, Current Input, 70dB typical@50mA p-p@50/60Hz; Voltage Input, 70dB typical@1V p-p@50/60Hz

Adjustments Front panel pushbuttons control settings for zero, span, alarm trip points, high/low alarms, etc.; Internal jumper and menu password protect parameter settings

Indicators LCD: 2x5 14-segment characters, backlit, alphanumeric readout accurate to the nearest digit.
Range: -99999 to 99999; Decimal point can be user-set
LED Type: INPUT LED: Dual color LED indicates input failure
READY LED: Green LED indicates unit is operating properly
ALARM 1, 2, 3 and 4 LED: Dual color LED per relay indicates alarm status

Weight 544 g to 601 g (19.2 oz to 21.2 oz)

Table 1. Long-Term Stability

Stability (% of Maximum Span)	Input-to-Output (Years)			Input-to-Relay (Years)		
	1	3	5	1	3	5
Current Inputs	0.081	0.14	0.18	0.047	0.081	0.105
Voltage Inputs	0.093	0.16	0.21	0.066	0.114	0.147

SPA²

Programmable Current/Voltage
and RTD/Thermocouple Limit Alarm Trips

Specifications (TPRG: RTD, T/C, Ohm, mV and Potentiometer Input Model)

<p>Performance</p> <p>Alarm Trip Repeatability: Refer to Table 2 Display Accuracy: ±1 digit; when scaling the display (or in custom mode), high input-to-display span ratios decrease display accuracy Input Accuracy: Refer to Table 2 Reference Junction Compensation Accuracy (T/C inputs only): ±0.45°C Stability: Refer to Table 3 Dead Band: User set within selected input range; fully scaleable and set in user-selected engineering units Response Time: 256msec maximum (Defined as the time from step change on input to alarm state change when alarm is set to trip mid-point) Alarm Trip Delay: Programmable from 0-120 seconds Line Voltage Effect: ±0.002% of span for a 1% change in line voltage (AC or DC) Isolation: 1000Vrms between case, input, output (units with -AO option) and power, continuous. Will withstand a 1200Vac dielectric strength test for one minute (with no breakdown) WITH -RF OPTION: 500Vrms between case, input, output and power Power Supply: 24DC range, 18-30Vdc; UAC range, 90-260Vac; 110DC range, 75-150Vdc Power Consumption: 3.5W maximum (24DC supply); 4W maximum</p>	<p>Performance (continued)</p> <p>(UAC supply); 6W maximum (110DC supply) Input Over-Range Protection: ±5Vdc Input Impedance: T/C inputs, 40 Mohms, nominal Input Over-Range Protection: ±5Vdc Excitation Current: (RTD and Ohms) 250 microamps, ±10%</p> <p>Performance with Analog Output (-AO Option)</p> <p>WITH ANALOG OUTPUT Output Accuracy: Current, ±0.01% of maximum span (±2 microamps); Voltage, ±0.01% of maximum span (±1mV) Response Time: 256msec maximum (128msec typical) for the output to change from 10% to 90% of its scale for an input step change of 0 to 100% Ripple (up to 120Hz): Current output, 10mVp-p when measured across a 250ohm resistor; Voltage output, 50mVp-p maximum Output Limiting: Current outputs, <table border="1" data-bbox="714 1249 933 1281"> <thead> <tr> <th>Output</th> <th>Failure Limits</th> </tr> </thead> <tbody> <tr> <td>0-20mA</td> <td>0, 23.6mA</td> </tr> <tr> <td>4-20mA</td> <td>3.6, 23.6mA</td> </tr> <tr> <td>X-20mA</td> <td>(90% of X), 23.6mA</td> </tr> </tbody> </table> Voltage output, -0.5-11V Load Effect (current outputs): ±0.01% of span from 0 to 1000 ohms resistance on current output</p> <p>Ambient Conditions</p> <p>Operating Range: -40°C to +85°C (-40°F to +185°F) Relay Range: -25°C to +70°C (-13°F to +158°F) Storage Range: -40°C to +85°C (-40°F to +185°F)</p>	Output	Failure Limits	0-20mA	0, 23.6mA	4-20mA	3.6, 23.6mA	X-20mA	(90% of X), 23.6mA	<p>Ambient Conditions (continued)</p> <p>Ambient Temperature Effect: Refer to Table 4 Effect of Ambient Temperature on Reference Junction Compensation (T/C inputs only): ±0.005% per °C change of ambient temperature Relative Humidity: 0-95%, non-condensing RF/EMI Protection: 10V/m@80-1000MHz, 1kHz AM, when tested to IEC61326 with 0.5% of span or less error WITH -RF OPTION: 20V/m@80-1000MHz, 1kHz AM, when tested to IEC61326 with 0.5% of span or less error Noise Rejection: Common Mode, 100dB@50/60Hz Normal Mode, refer to Table 5</p> <p>Adjustments</p> <p>Front panel pushbuttons control settings for zero, span, alarm trip points, high/low alarms, etc.; Internal jumper and menu password protect parameter settings</p> <p>Indicators</p> <p>LCD: 2x5 14-segment characters, backlit, alphanumeric readout accurate to the nearest digit. Range: -99999 to 99999; Decimal point can be user-set LED Type: INPUT LED: Dual color LED indicates input failure READY LED: Green LED indicates unit is operating properly ALARM 1, 2, 3 and 4 LED: Dual color LED per relay indicates alarm status</p> <p>Weight</p> <p>544 g to 601 g (19.2 oz to 21.2 oz)</p>
Output	Failure Limits									
0-20mA	0, 23.6mA									
4-20mA	3.6, 23.6mA									
X-20mA	(90% of X), 23.6mA									

Table 2. Accuracy with RTD, Thermocouple, Ohms, and Millivolt Inputs (Models with TPRG Input)

Input	Type	α	Ohms	Conformance Range	Minimum Span	Input Accuracy/ Repeatability	Maximum Range		
RTD (2-, 3-, 4-Wire)	Platinum	0.003850	100	-200 to 850°C (-328 to 1562°F)	10°C (18°F)	±0.1°C (±0.18°F)	-240 to 960°C (-400 to 1760°F)		
			200						
			300						
			400						
			500						
			1000						
		Dual 500	-200 to 260°C (-328 to 500°F)	-200 to 260°C (-328 to 500°F)					
		Dual 1000	-200 to 440°C (-328 to 824°F)	-200 to 440°C (-328 to 824°F)					
		Triple 500	-200 to 80°C (-328 to 176°F)	-200 to 80°C (-328 to 176°F)					
		Triple 1000	0.003902	100	-100 to 650°C (-148 to 1202°F)	10°C (18°F)	±0.85°C (±1.53°F)	-150 to 720°C (-238 to 1328°F)	
		200							
		400							
		500							
		1000							
		Dual 500		-100 to 260°C (-148 to 500°F)					-100 to 260°C (-148 to 500°F)
Dual 1000	-100 to 440°C (-148 to 824°F)	-100 to 440°C (-148 to 824°F)							
Triple 500	-100 to 80°C (-148 to 176°F)	-100 to 80°C (-148 to 176°F)							
Triple 1000	0.003916	100	-200 to 510°C (-328 to 950°F)	10°C (18°F)	±0.85°C (±1.53°F)	-240 to 580°C (-400 to 1076°F)			
Nickel		0.00672					120	-80 to 320°C (-112 to 608°F)	-100 to 360°C (-148 to 680°F)
Copper		0.00427					9.035	-50 to 250°C (-58 to 482°F)	-65 to 280°C (-85 to 536°F)
Ohms	Direct Resistance	n/a	0-4000	0-4000 ohms	10 ohms	±0.4 ohms	0-4095 ohms		
			Dual 0-2000 ohms	0-2000 ohms			0-2000 ohms		
			Triple 0-1300 ohms	0-1300 ohms			0-1300 ohms		
	Potentiometer		4000 maximum	0-100%			10%	±0.1%	0-100%
T/C	J	n/a	n/a	-180 to 760°C (-292 to 1400°F)	35°C (63°F)	±0.25°C (±0.45°F)	-210 to 770°C (-346 to 1418°F)		
	K	n/a	n/a	-150 to 1370°C (-238 to 2498°F)	40°C (72°F)	±0.3°C (±0.54°F)	-270 to 1390°C (-454 to 2534°F)		
	E	n/a	n/a	-170 to 1000°C (-274 to 1832°F)	35°C (63°F)	±0.2°C (±0.36°F)	-270 to 1013°C (-454 to 1855.4°F)		
	T	n/a	n/a	-170 to 400°C (-274 to 752°F)	35°C (63°F)	±0.25°C (±0.45°F)	-270 to 407°C (-454 to 764.6°F)		
	R	n/a	n/a	0 to 1760°C (32 to 3200°F)	50°C (90°F)	±0.55°C (±0.99°F)	-50 to 1786°C (-58 to 3246.8°F)		
	S	n/a	n/a	0 to 1760°C (32 to 3200°F)	50°C (90°F)	±0.55°C (±0.99°F)	-50 to 1786°C (-58 to 3246.8°F)		
	B	n/a	n/a	400 to 1820°C (752 to 3308°F)	75°C (135°F)	±0.75°C (±1.35°F)	200 to 1836°C (392 to 3336.8°F)		
	N	n/a	n/a	-130 to 1300°C (-202 to 2372°F)	45°C (81°F)	±0.4°C (±0.72°F)	-270 to 1316°C (-454 to 2400.8°F)		
	C	n/a	n/a	0 to 2300°C (32 to 4172°F)	100°C (180°F)	±0.8°C (±1.44°F)	0 to 2338°C (32 to 4240.4°F)		
mV	DC	n/a	n/a	n/a	4mV	±30 microvolts	-50 to 1000mV		

SPA²

Programmable Current/Voltage and RTD/Thermocouple Limit Alarm Trips

Ordering Information

Unit	Input	Output	Power	Options	Housing
SPA2 Programmable Limit Alarm Trip	<p>HLPRG Programs to accept:</p> <p>Current: Any range between 0-50mA including: 0-20mA 4-20mA 10-50mA</p> <p>Voltage: Any range between 0-10Vdc including: 0-5Vdc 1-5Vdc 0-10Vdc</p> <p>TPRG Programs to accept (see Table 2 for details):</p> <p>RTD: 2-, 3- and 4-wire; platinum, copper, and nickel</p> <p>Thermocouple: J, K, E, T, R, S, N, C, B</p> <p>Ohms: 0-4000ohms (Potentiometer, 4000ohms maximum)</p> <p>Millivolts: -50 to +1000mV</p>	<p>2PRG Dual Relays (Relays are single-pole/double-throw (SPDT, 1 form C, rated 5A@250Vac, 50/60Hz or 24Vdc, non-inductive)</p> <p>4PRG Quad Relays (Relays are single-pole/double-throw (SPDT), 1 form C, rated 5A@250Vac, 50/60Hz or 24Vdc, non-inductive)</p> <p>Each relay individually configures for: High or Low Trip Normally Open or Normally Closed Failsafe or Non-Failsafe</p>	<p>24DC ±10% 110DC 75-150DC UAC Accepts any power input range between 90-260Vac</p>	<p>-AO Analog output (isolated and linearized) scaleable for any range between 0-20mA into 1000 ohms or 0-10V into 10 kohms (see "Specifications" for additional information) NOTE: Current output can be user-set for internal or external power (source or sink)</p> <p>-DPDT Relays are double-pole/double-throw (DPDT), 2 form C, rated 5A@250Vac, 50/60Hz or 24Vdc, non-inductive (2PRG output model only)</p> <p>-RF Enhanced RFI/EMI protection (see "Specifications" for details)</p> <p>-FMEDA Unit comes with Failure Modes, Effects and Diagnostic Analysis (FMEDA) data for evaluating the instrument for suitability of use in a safety-related application</p>	<p>DIN Universal DIN-style housing mounts on 32mm (EN50035) G-type and 35mm (EN50022) Top Hat DIN-rails</p> <p>FLD Externally-mounted flange provides a secure mount</p>

When ordering, specify: Unit / Input / Output / Power / Options [Housing]

Model number example: SPA2 / TPRG / 2PRG / 24DC / - AO -RF [DIN]

Table 3. Long-Term Stability

Stability (% of Maximum Span)	Input-to-Output (Years)			Input-to-Relay (Years)		
	1	3	5	1	3	5
RTD, Ohm & Pot Inputs	0.09	0.16	0.21	0.047	0.081	0.104
T/C & mV Inputs	0.08	0.14	0.18	0.008	0.014	0.019

Table 5. Normal Mode Rejection Ratio

Sensor Type	Max. p-p Voltage Injection for 100dB at 50/60Hz
T/C: J, K, N, C, E	150mV
T/C: T, R, S, B	80mV
Pt RTD: 100, 200, 300 ohms	250mV
Pt RTD: 400, 500, 1000 ohms	1V
Ni: 120 ohms	500mV
Cu: 9.03 ohms	100mV
Resistance	mV
1-4 kohms	250-1000
0.25-1 kohms	62.5-250
0.125-0.25 kohms	31.25-62.5

Table 4. Ambient Temperature Effect

	Accuracy per 1°C (1.8°F) Change in Ambient
RTD*	0.0035°C
Millivolt	0.5 microvolts + 0.005% of reading
Ohm	0.002 ohms + 0.005% of reading
Thermocouple	
	Accuracy per 1°C (1.8°F) Change in Ambient
J	0.00016°C + 0.005% of reading
K	0.0002°C + 0.005% of reading
E	0.00026°C + 0.005% of reading
T	0.0001°C + 0.005% of reading
R, S	0.00075°C + 0.005% of reading
B	0.0038°C + 0.005% of reading
N	0.003°C + 0.005% of reading
C	0.00043°C + 0.005% of reading
mV	0.5 microvolts + 0.005% of reading

*Accuracy of Ni672 is 0.002°C

Figure 11. Installation Dimensions

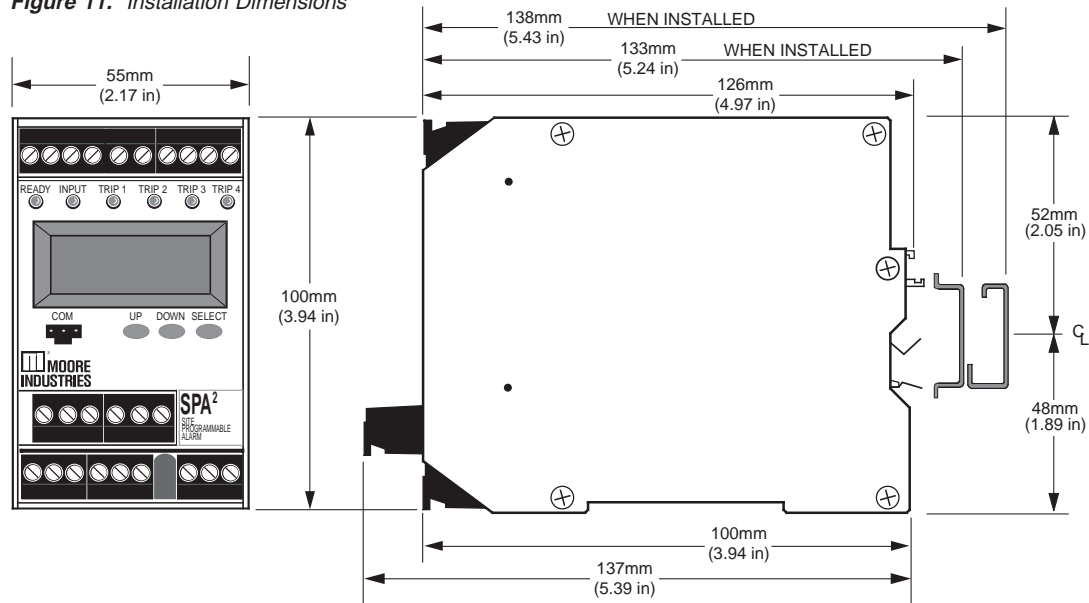

NOTE: While all SPA² models (model with HPRG input shown) are dimensionally identical, the SPA² that accepts temperature inputs (TPRG input) features metal terminal blocks for enhanced reference junction compensation.

Figure 12. Temperature Sensor Hook-Up Guide (Models with TPRG Input)

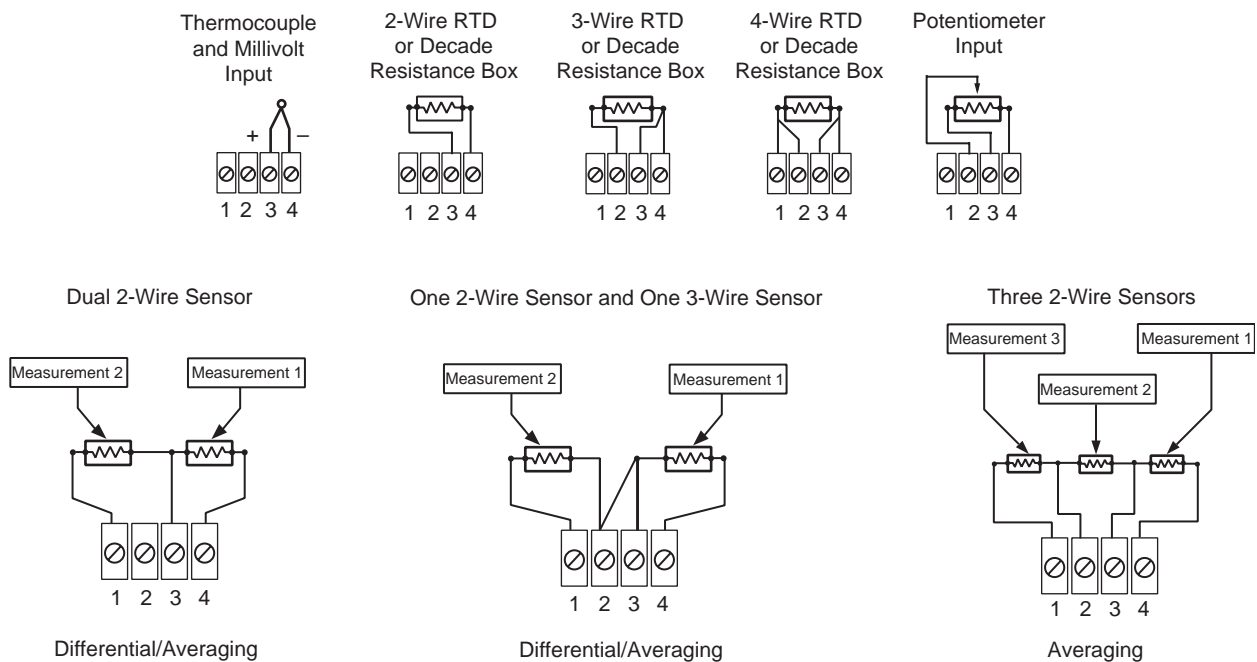

SPA²

Programmable Current/Voltage and RTD/Thermocouple Limit Alarm Trips

Table 6. Terminal Designations (Models with TPRG Input)

Input Type	Top Terminals (Left to Right)									
	T1	T2	T3	T4	T5	T6	T7	T8	T9	T10
RTD, Ohm, Potentiometer, T/C & mV Inputs	See Figure 12				MR	MR	+I _o Source	-I _o Source +I _o Sink	+V _o	-V _o -I _o Sink

Output Type	Middle Terminals (Left to Right)					
	11	12	13	14	15	16
2PRG (SPDT Relays)	N/A	N/A	N/A	N/A	N/A	N/A
4PRG (SPDT Relays)	NO3	CM3	NC3	NO4	CM4	NC4
2 DPDT Relays	Relay 2 NO1	Relay 2 CM1	Relay 2 NC1	Relay 2 NO2	Relay 2 CM2	Relay 2 NC2

Output/Power Type	Bottom Terminals (Left to Right)									
	B1	B2	B3	B4	B5	B6	B7	B8	B9	B10
2PRG (SPDT Relays)	NO1	CM1	NC1	NO2	CM2	NC2	Not Used	AC or DC	ACC or DCC	GND
4PRG (SPDT Relays)	NO1	CM1	NC1	NO2	CM2	NC2	Not Used	AC or DC	ACC or DCC	GND
2 DPDT Relays	Relay 1 NO1	Relay 1 CM1	Relay 1 NC1	Relay 1 NO2	Relay 1 CM2	Relay 1 NC2	Not Used	AC or DC	ACC or DCC	GND

NOTES:

- Terminal blocks can accommodate 14-22 AWG solid wiring, tighten to four inch-pounds (maximum).
- $\pm I_o/\pm V_o$ labeling is present only when the unit is equipped with the Analog Output (-AO) option.
- Your input power requirement (AC or DC / ACC or DCC) will depend upon your unit's power need.

KEY:

AC or DC = Power Input	I _o = Current Output	Sink = Current Sink
ACC or DCC = Power Input	MR = Manual Reset	Source = Current Source
CM = Relay Common	NO = Normally Open	SPDT = Single-Pole/Double-Throw
DPDT = Double-Pole/Double-Throw	NC = Normally Closed	V _o = Voltage Output
GND = Ground (case)		

Accessories

Each SPA² order comes with one copy of our Intelligent PC Configuration Software (Windows® '95, '98, 2000, NT and XP compatible) and a configuration cable. Use the chart below to order additional parts.

Part Number 750-75E05-01	Intelligent PC Configuration Software (One copy provided free with each order)
Part Number 803-053-26	Configuration Cable for use in connecting the SPA ² to a PC (one cable provided free with each order)

Table 7. Terminal Designations (Models with HLPRG Input)

Input Type	Top Terminals (Left to Right)									
	T1	T2	T3	T4	T5	T6	T7	T8	T9	T10
Current Input	Tx	+I	COM	Not Used	MR	MR	+Io Source	-Io Source +Io Sink	+Vo	-Vo -Io Sink
Voltage Input	Tx	Not Used	COM	+V	MR	MR	+Io Source	-Io Source +Io Sink	+Vo	-Vo -Io Sink

Output Type	Middle Terminals (Left to Right)					
	11	12	13	14	15	16
2PRG (SPDT Relays)	N/A	N/A	N/A	N/A	N/A	N/A
4PRG (SPDT Relays)	NO3	CM3	NC3	NO4	CM4	NC4
2 DPDT Relays	Relay 2 NO1	Relay 2 CM1	Relay 2 NC1	Relay 2 NO2	Relay 2 CM2	Relay 2 NC2

Output/Power Type	Bottom Terminals (Left to Right)									
	B1	B2	B3	B4	B5	B6	B7	B8	B9	B10
2PRG (SPDT Relays)	NO1	CM1	NC1	NO2	CM2	NC2	Not Used	AC or DC	ACC or DCC	GND
4PRG (SPDT Relays)	NO1	CM1	NC1	NO2	CM2	NC2	Not Used	AC or DC	ACC or DCC	GND
2 DPDT Relays	Relay 1 NO1	Relay 1 CM1	Relay 1 NC1	Relay 1 NO2	Relay 1 CM2	Relay 1 NC2	Not Used	AC or DC	ACC or DCC	GND

NOTES:

- Terminal blocks can accommodate 14-22 AWG solid wiring, tighten to four inch-pounds (maximum).
- $\pm I_o/\pm V_o$ labeling is present only when the unit is equipped with the Analog Output (-AO) option.
- Your input power requirement (AC or DC / ACC or DCC) will depend upon your unit's power need.

KEY:

AC/DC = Power Input	I = Current Input	Source = Current Source
ACC/DCC = Power Input	Io = Current Output	SPDT = Single-Pole/Double-Throw
CM = Relay Common	MR = Manual Reset	TX = Power for 2-wire transmitter
COM = Analog Common	NO = Normally Open	V = Voltage Input
DPDT = Double-Pole/Double-Throw	NC = Normally Closed	Vo = Voltage Output
GND = Ground (case)	Sink = Current Sink	

SPA²

Programmable Current/Voltage
and RTD/Thermocouple Limit Alarm Trips

Six Universal Instruments in One!

- 1 Dual and Quadruple Limit Alarm Trip
- 2 Analog or Temperature Transmitter
- 3 Signal Isolator and Converter
- 4 Local Process Display in Engineering Units
- 5 Linearizing, Averaging, Differential, and Rate-of-Change Computation Module
- 6 2-Wire Transmitter Power Supply (Transmitter Excitation)



Universal Alarm Trip Solution

There's no need to specify and stock an array of single-function alarm trips. Our SPA² is the perfect solution:

- Standardize on, and stock just one, universal instrument for all of your alarm trip needs.
- Warn of trouble by providing an alarm output when a process signal exceeds a high and/or low limit.
- Provide dependable, redundant warning and/or shutdown capabilities to compensate for a DCS or PLC failure.
- Use combination alarm trip/transmitter models to reduce costs when both alarming and monitoring functions are needed at the same location.
- Sense dangerous conditions and shut down control equipment before it is damaged.
- Compare two variables and trip an alarm when the difference between the two exceeds a preset value.
- Install multi-trip alarms to provide several levels of warning and shutdown action.
- Use for reliable and cost-effective on/off control of pumps and motors.
- Create custom, 128 point linearization curves to compensate for non-linear measurements and instruments.
- Keep track of sensor operation and quickly diagnose sensor failures with our patented *Total Sensor Diagnostics*.



WORLDWIDE • www.miinet.com

United States • info@miinet.com
Tel: (818) 894-7111 • FAX: (818) 891-2816
Australia • sales@mooreind.com.au
Tel: (02) 8536-7200 • FAX: (02) 9525-7296

Belgium • info@mooreind.be
Tel: 03/448.10.18 • FAX: 03/440.17.97
The Netherlands • sales@mooreind.nl
Tel: (0)344-617971 • FAX: (0)344-615920

China • sales@mooreind.sh.cn
Tel: 86-21-62491499 • FAX: 86-21-62490635
United Kingdom • sales@mooreind.com
Tel: 01293 514488 • FAX: 01293 536852