

Pressure Measurement

Transmitters for applications with advanced requirements (Advanced)
SITRANS P320/P420

Technical description

1

Overview



SITRANS P320/P420 pressure transmitters are digital pressure transmitters featuring extensive user-friendliness and high accuracy. The parameter assignment is performed using input buttons or the HART interface.

The comprehensive functionality makes for precise adjustment of the pressure transmitter to the requirements of the plant. Operation is very user-friendly in spite of the numerous setting options.

Due to their advanced diagnostic functionalities according to NAMUR NE107, the SITRANS P320/P420 pressure transmitters are very suitable for use in chemical plants. Thanks to the advanced diagnostic functions and the process value storage, the SITRANS P420 is "Ready for Digitalization".

The "Remote Safety Handling" function saves customers significant amounts of time and money, because the SIL function can be switched on and validated remotely via SIMATIC PDM. This eliminates travel times and on-site operation via the local display or keyboard.

Parameter assignment using the HART protocol is very easy and quick thanks to the innovative EDD with integrated Quick Start wizard.

The transmitters can be equipped with various types of remote seals for special applications such as the measurement of highly viscous substances.

SITRANS P320/P420 pressure transmitters are available in various versions for measuring:

- Gauge pressure
- Absolute pressure
- Differential pressure
- Level
- Volume flow
- Mass flow

Benefits

- Diagnostic functions in accordance with NAMUR recommendation NE107
- SIL devices developed according to IEC 61508
- SIL validation on the device or remotely with SIMATIC PDM
- Reduction of internal inductance for Ex applications to LI = 0
- Step response time for pressure type T63 = 105 ms and for differential pressure type 135 ms.
- Minimal conformity error
- Very low temperature influence
- Very good long-term stability
- High quality and service life
- High reliability even under extreme chemical and mechanical loads
- For corrosive and non-corrosive gases, vapors and liquids
- Extensive diagnostics and simulation functions
- Separate replacement of measuring cell and electronics without recalibration
- Wetted parts made of high-grade materials (e.g., stainless steel, alloy, gold, Monel, tantalum)
- Infinitely adjustable spans from 0.01 bar to 700 bar (0.15 psi to 10153 psi)
- Convenient parameterization over 4 input buttons and HART interface

Application

SITRANS P320/P420 pressure transmitters can be used in industrial areas with extreme chemical and mechanical loads.

The pressure transmitters can be used in zone 1 or zone 0 with the corresponding Ex approval.

The transmitters can be equipped with various designs of remote seals for special applications such as the measurement of highly viscous substances.

The pressure transmitter can be operated locally over 4 input buttons or programmed externally over HART interface.

Pressure transmitter for gauge pressure

Measured variable:

- Gauge pressure of corrosive and non-corrosive gases, vapors and liquids.

Span (infinitely adjustable)

- For SITRANS P320/P420 with HART: 0.01 bar to 700 bar (0.15 psi to 10153 psi)

There are two series:

- Gauge pressure series
- Differential pressure series

Pressure transmitters for absolute pressure

Measured variable:

- Absolute pressure of corrosive and non-corrosive gases, vapors and liquids.

Span (infinitely adjustable)

- For SITRANS P320/P420 with HART: 8.3 mbar a to 100 bar a (0.12 to 1450 psi a)

There are two series:

- Gauge pressure series
- Differential pressure series

Pressure transmitters for differential pressure and flow

Measured variables:

- Differential pressure
- Small positive or negative overpressure
- Flow $q \sim \sqrt{\Delta p}$ (together with a primary differential pressure transducer (see section "Flow meters"))

Span (infinitely adjustable)

- For SITRANS P320/P420 with HART: 1 mbar to 30 bar (0.0145 to 435 psi)

Pressure transmitters for level

Measured variable:

- Level of corrosive and non-corrosive liquids in open and closed vessels.

Span (infinitely adjustable)

- For SITRANS P320/P420 with HART: 25 mbar to 5 bar (0.363 to 72.5 psi)

Type of the mounting flange:

- EN 1092-1 flanges
- ASME B16.5 flanges
- J.I.S. flanges
- Diverse range of sealing surface forms available

Design

Depending on the customer-specific order, the device comprises different parts.

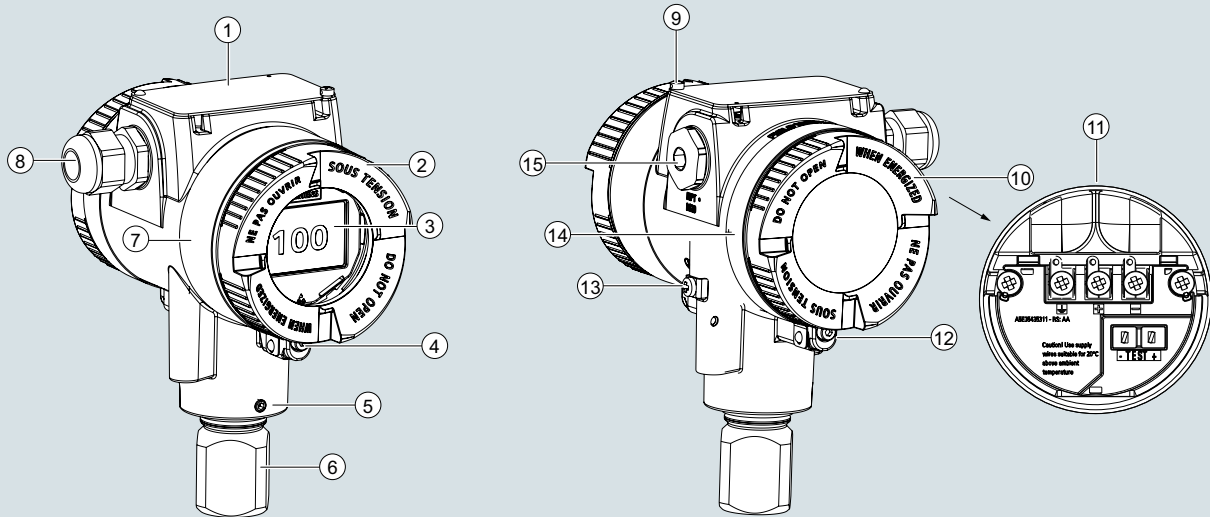

- ① Cover over buttons and nameplate with general information
- ② Cover (front), optionally with inspection window
- ③ Display (optional)
- ④ Safety catch (front)
- ⑤ Retaining screw for rotation of the enclosure
- ⑥ Process connection
- ⑦ Nameplate with approval information
- ⑧ Cable inlet, optionally with cable gland

- ⑨ Screw for the cover over the buttons
- ⑩ Cover (rear) for electrical terminal compartment
- ⑪ Electrical terminal compartment
- ⑫ Safety catch (back)
- ⑬ Ground terminal
- ⑭ Nameplate with information on the remote seal
- ⑮ Blanking plug

Device front view

- The electronics enclosure is made of die cast aluminum or precision cast stainless steel.
- The housing has a removable circular cover at the front and the back.
- Depending on the device version, the front cover (2) may be designed as an inspection window.
- The cable inlet (8) to the electrical terminal compartment is at the side; either the left or right-hand one can be used. The unused opening is closed with a blanking plug (15).
- The ground terminal (13) is located on the side.

- The electrical terminal compartment (11) for the auxiliary power and shield is accessible when you remove the back cover (10).
- The measuring cell with process connection (6) is located in the bottom part of the enclosure. The measuring cell is prevented from rotating by a locking screw (5).
- Thanks to the modular design of the pressure transmitter, the measuring cell and application electronics or terminal compartment can be replaced if required.
- The cover over buttons (1), under which there are 4 buttons, is located on the upper face of the enclosure. The nameplate with general information is located on the cover over the buttons.

Pressure Measurement

Transmitters for applications with advanced requirements (Advanced)
SITRANS P320/P420

1

Technical description

Nameplates

Nameplate

The nameplate with the article no. and other important information, such as design details and technical data, is located on the cover over the buttons.

SIEMENS

SITRANS P320
Transmitter for pressure
7MF0440-1ML02-5BF0-Z
B11+E20
F.-Nr. XXXXXXXXX

Vh: DC 10.5 ... 45 V (non IS) 4 ... 20 mA HART
Mat.: Connec. Diaphr.. O-ring Filling
1.4404 FPM (FKM) Silicone oil

Min./Max. Measuring span : 16 mbar/1600 mbar
Rated pressure : PN 160

Type of protection IP66
PED:SEP FW: 00.02.04 HW: 00.00.01

Siemens AG, DE-76181 Karlsruhe
Made in France

① Article No.
② Serial number
③ Materials, connection, diaphragm, O-ring, oil
④ Minimum/maximum measuring span
⑤ Nominal pressure
⑥ Degree of protection
⑦ Conformity with country-specific directives
⑧ QR code to mobile website with device-specific information

Nameplate with approval information

The nameplate with approval information is located on the front of the enclosure.

II 1/2 G Ex ia IIC T4/T5/T6 Ga
II 1/2 G Ex Ib IIC T4/T5/T6 Gb
VH: DC 10.5 ... 45 V outp.: 4 ... 20 mA
from certified intrinsically safe power source
VI ≤ 30 V ; II ≤ 100 mA ; PI ≤ 0.75 W
LI ≤ 0.4 mH ; CI ≤ 6 nF

PTB XX ATEX XXXX
Note test certificate I
-40°C ≤ Ta ≤ +60°C (T8) / +85°C (T4)

II 1/2 G Ex ia IIC T4/T5/T6 Ga

① Characteristics of the hazardous area
② Type of protection
③ Group (gas, dust)
④ Maximum surface temperature (temperature class)
⑤ Device protection level

Measuring point label

The measuring point label is located under the front cover.

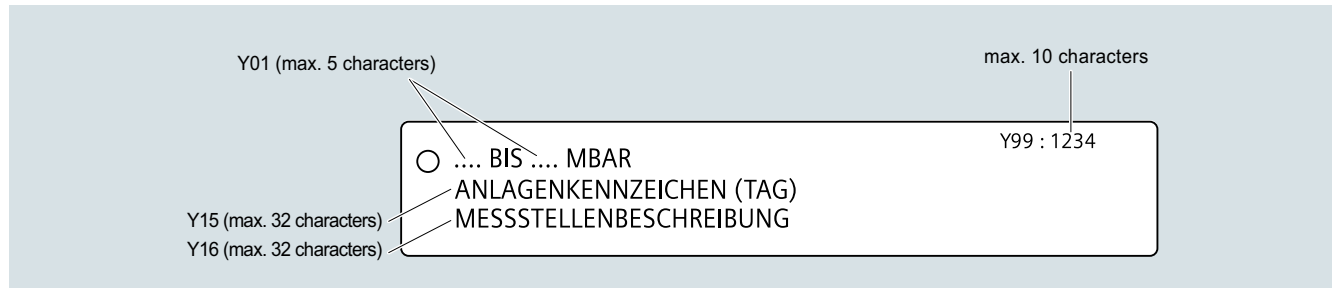
Nameplate with information on the remote seals

The nameplate with information on the remote seals is located on the back of the enclosure.

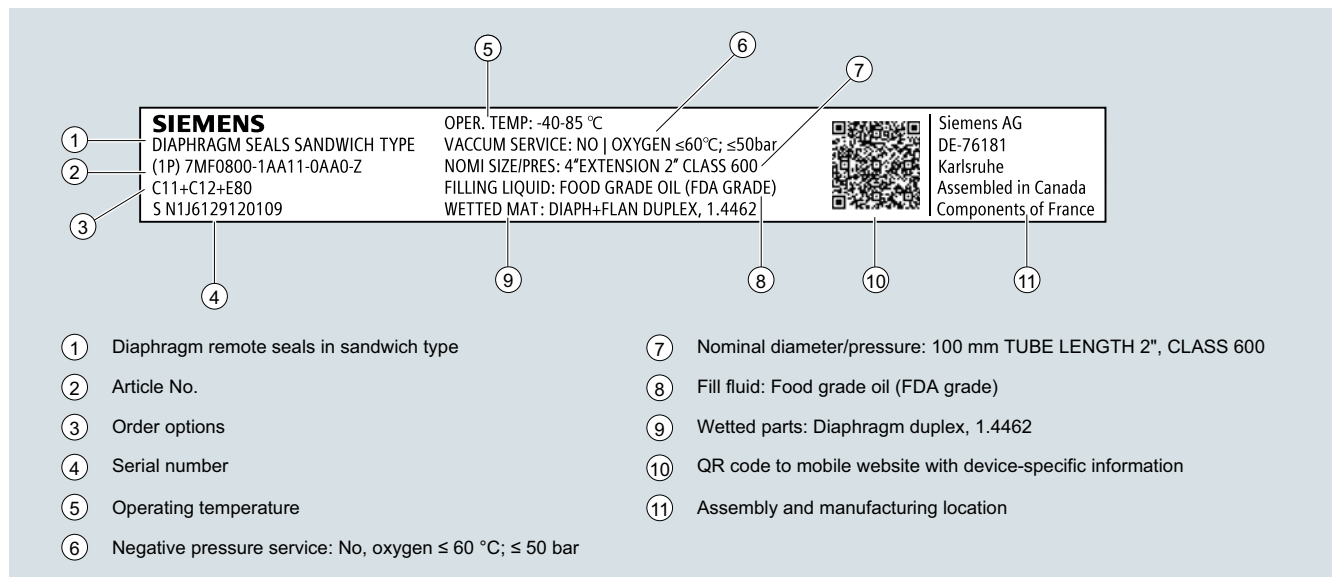

Pressure Measurement

Transmitters for applications with advanced requirements (Advanced)
SITRANS P320/P420

Technical description

Function

Adjustable parameters and diagnostics

SITRANS P320/P420 with HART communication

Parameters	Input buttons	SITRANS P320	SITRANS P420
Application, measurement type	x	x	x
Adjusting start of scale value/full scale value	x	x	x
Setting start of scale value/full scale value	x	x	x
Electrical damping	x	x	x
Zero adjustment	x	x	x
Fault current	x	x	x
Saturation limits	x	x	x
Scaling of the display	x	x	x
Characteristic selection	x	x	x
Temperature unit	x	x	x
Key lock	x	x	x
Change user pin	x	x	x
Functional safety	x	x	x
Loop test	x	x	x
Start view	x	x	x
Pressure reference	x	x	x
Reset	x	x	x
Diagnostics and trend log			
Min/Max pointer		x	x
Limit monitoring			2
Event counter (overflow/underflow)			2
Trend log			2, max. 1 500 values

Available physical units of display for SITRANS P320/P420

Physical variable	Physical dimensions
Pressure (setting can also be made in the factory)	Pa, MPa, kPa, hPa, bar, mbar, psi, g/cm ² , kg/cm ² , kgf/cm ² , inH ₂ O, inH ₂ O (4 °C), ftH ₂ O, mmH ₂ O, mmH ₂ O (4 °C), mH ₂ O (4 °C), mmHg, inHg, atm, torr
Level (height data)	m, cm, mm, ft, in
Volumes (fill level)	m ³ , l, hl, in ³ , ft ³ , yd ³ , gal, gal (UK), bu, bbl, bbl (US), SCF, Nm ³ , NI
Volume (flow)	m ³ /sec, m ³ /h, m ³ /d, l/sec, l/min, l/h, Ml/d, ft ³ /sec, ft ³ /h, ft ³ /d, SCF/min, SCF/h, NI/h, Nm ³ /hgal/sec, gal/min, gal/h, gal/d, Mgal/d, gal (UK)/sec, gal (UK)/min, gal (UK)/h, gal (UK)/d, bbl/sec, bbl/min, bbl/h, bbl/d
Mass (flow)	Kg/sec, kg/min, kg/h, kg/d, g/sec, g/min, g/h, t/min, t/h, t/d, lb/sec, lb/min, lb/h, lb/d, ton/min, ton/h, ton/d, ton (UK)/h, ton (UK)/d
Temperature	°C, °F
Miscellaneous	%, mA, free text max. 12 characters

For more device information and technical specifications, refer to the individual device versions.

Pressure Measurement

Transmitters for applications with advanced requirements (Advanced)

SITRANS P320/P420

for gauge pressure (pressure series)

1

Technical specifications**SITRANS P320 / SITRANS P420 for gauge pressure (pressure series)****Input**

Measured variable	Gauge pressure		
Span (infinitely adjustable) or measuring range, max. permissible operating pressure (in accordance with Pressure Equipment Directive 2014/68/EU) and max. test pressure (pursuant to DIN 16086) (for oxygen measurement, max. 100 bar/ 10 MPa/1450 psi and 60 °C (140 °F) ambient temperature/process temperature)	Span	Max. permissible operating pressure MAWP (PS)	Maximum permissible test pressure
	8.3 ... 250 mbar	4 bar	6 bar
	0.83 ... 25 kPa	0.4 MPa	0.6 MPa
	0.12 ... 3.6 psi	58 psi	87 psi
	0.01 ... 1 bar	6 bar	9 bar
	1 ... 100 kPa	0.6 MPa	0.9 MPa
	0.15 ... 14.5 psi	87 psi	130 psi
	0.04 ... 4 bar	20 bar	30 bar
	4 ... 400 kPa	2 MPa	3 MPa
	0.58 ... 58 psi	290 psi	435 psi
	0.16 ... 16 bar	45 bar	70 bar
	0.016 ... 1.6 MPa	4.5 MPa	7 MPa
	2.3 ... 232 psi	652 psi	1015 psi
	0.63 ... 63 bar	80 bar	120 bar
	0.063 ... 6.3 MPa	8 MPa	12 MPa
	9.1 ... 914 psi	1160 psi	1740 psi
	1.6 ... 160 bar	240 bar	380 bar
	0.16 ... 16 MPa	24 MPa	38 MPa
	23 ... 2321 psi	3480 psi	5511 psi
	4 ... 400 bar	400 bar	600 bar
0.4 ... 40 MPa	40 MPa	60 MPa	
58 ... 5802 psi	5802 psi	8702 psi	
7 ... 700 bar	800 bar	800 bar	
0.7 ... 70 MPa	80 MPa	80 MPa	
102 ... 10153 psi	11603 psi	11603 psi	
Measuring limits	For 250 mbar/25 kPa/3.6 psi measuring cells, the lower measuring limit is 750 mbar a/75 kPa a/10.8 psi a. The measuring cell is vacuum-resistant up to 30 mbar a/3 kPa a/0.44 psi a.		
• Low measuring limit	<ul style="list-style-type: none"> - Measuring cell with silicone oil filling 30 mbar a/3 kPa a/0.44 psi a - Measuring cell with inert oil 30 mbar a/3 kPa a/0.44 psi a - Measuring cell with FDA-compliant oil 100 mbar a/10 kPa a/1.45 psi a 		
• Upper measuring limit	100% of the max. measuring span (for oxygen measurement max. 100 bar/10 MPa/ 1450 psi and 60 °C (140 °F) ambient temperature/process temperature)		
• Start of scale	Between the measuring limits (infinitely adjustable)		

Output

Output signal	HART
• Low saturation limit (infinitely adjustable)	4 ... 20 mA
• High saturation limit (infinitely adjustable)	3.55 mA, factory preset to 3.8 mA
• Ripple (without HART communication)	22.8 mA, factory-set to 20.5 mA or optionally 22.0 mA
Adjustable damping	$I_{pp} \leq 0.5\%$ of max. output current
• Current transmitter	0 ... 100 s, continuously adjustable over remote operation
• Failure signal	0 ... 100 s, in increments of 0.1 s, adjustable over display
Load	3.55 ... 22.8 mA
• Without HART communication	3.55 ... 22.8 mA
• With HART communication	Resistor R [Ω]
Characteristic curve	$R = (U_H - 10.5 \text{ V})/22.8 \text{ mA}$, U_H : Power supply in V
Physical bus	R = 230 ... 1100 Ω (HART communicator (handheld))
Polarity-independent	R = 230 ... 500 Ω (SIMATIC PDM)
	<ul style="list-style-type: none"> • Linearly increasing or linearly decreasing • Linear increase or decrease or according to the square root (only for differential pressure and flow)
	-
	-

Pressure Measurement

Transmitters for applications with advanced requirements (Advanced)

SITRANS P320/P420

for gauge pressure (pressure series)

SITRANS P320 / SITRANS P420 for gauge pressure (pressure series)

Measuring accuracy

Reference conditions

- According to EN 60770-1
- Rising characteristic curve
- Start of scale value 0 bar/kPa/psi
- Seal diaphragm stainless steel
- Measuring cell with silicone oil filling
- Room temperature 25 °C (77 °F)

Conformity error at limit point setting, including hysteresis and repeatability

Measuring span ratio r (spread, Turn-Down)

$r = \text{max. measuring span/set measuring span and nominal measuring range}$

- Linear characteristic

- 250 mbar/25 kPa/3.6 psi

$r \leq 1.25$: $\leq 0.075\%$ (SITRANS P320)
 $\leq 0.065\%$ (SITRANS P420)

- 1 bar/100 kPa/3.6 psi
 4 bar/400 kPa/58 psi
 16 bar/1.6 MPa/232 psi
 63 bar/6.3 MPa/914 psi
 160 bar/16 MPa/2321 psi

$1.25 < r \leq 30$: $\leq (0.008 \cdot r + 0.055)\%$
 $r \leq 5$: $\leq 0.065\%$ (SITRANS P320)
 $\leq 0.04\%$ (SITRANS P420)

- 400 bar/40 MPa/5802 psi
 700 bar/70 MPa/10152 psi

$5 < r \leq 100$: $\leq (0.004 \cdot r + 0.045)\%$
 $r \leq 3$: $\leq 0.075\%$ (SITRANS P320)
 $3 < r \leq 100$: $\leq (0.005 \cdot r + 0.05)\%$ (SITRANS P420)
 $r \leq 5$: $\leq 0.075\%$ (SITRANS P420)
 $5 < r \leq 100$: $\leq (0.005 \cdot r + 0.05)\%$ (SITRANS P420)

Influence of ambient temperature
 in % per 28 °C (50 °F)

- 250 mbar/25 kPa/3.6 psi
- 1 bar/100 kPa/3.6 psi
- 4 bar/400 kPa/58 psi
 16 bar/1.6 MPa/232 psi
 63 bar/6.3 MPa/914 psi
 160 bar/16 MPa/2321 psi
 400 bar/40 MPa/5802 psi
- 700 bar/70 MPa/10152 psi

$\leq (0.16 \cdot r + 0.1)\%$
 $\leq (0.05 \cdot r + 0.1)\%$
 $\leq (0.025 \cdot r + 0.125)\%$

Long-term stability at ± 30 °C (± 54 °F)

- 250 mbar/25 kPa/3.6 psi
- 1 bar/100 kPa/3.6 psi

$\leq (0.25 \cdot r)\%$ per year
 In 5 years $\leq (0.25 \cdot r)\%$
 In 10 years $\leq (0.35 \cdot r)\%$
 In 5 years $\leq (0.125 \cdot r)\%$
 In 10 years $\leq (0.15 \cdot r)\%$

- 4 bar/400 kPa/58 psi
 16 bar/1.6 MPa/232 psi
 63 bar/6.3 MPa/914 psi
 160 bar/16 MPa/2321 psi
 400 bar/40 MPa/5802 psi
- 700 bar/70 MPa/10152 psi

In 5 years $\leq (0.25 \cdot r)\%$
 In 10 years $\leq (0.35 \cdot r)\%$

Step response time T_{63} (without electrical damping)

Approx. 0.105 s

Effect of mounting position (in pressure per change of angle)

≤ 0.05 mbar/0.005 kPa/0.000725 psi per 10° incline
 (zero point correction is possible with position error compensation)

Effect of auxiliary power (in % per voltage change)

0.005% per 1 V

Pressure Measurement

Transmitters for applications with advanced requirements (Advanced)

SITRANS P320/P420

for gauge pressure (pressure series)

1

SITRANS P320 / SITRANS P420 for gauge pressure (pressure series)

Rated conditions

Temperature of medium

- Measuring cell with silicone oil filling -40 ... +100 °C (-40 ... +212 °F)
- Measuring cell with inert oil
 - 1 bar/100 kPa/3.6 psi -40 ... +85 °C (-40 ... +185 °F)
 - 4 bar/400 kPa/58 psi
 - 16 bar/1.6 MPa/232 psi
 - 63 bar/6.3 MPa/914 psi
 - 160 bar/16 MPa/2321 psi -20 ... +100 °C (-4 ... +212 °F)
 - 400 bar/40 MPa/5802 psi
 - 700 bar/70 MPa/10152 psi
- Measuring cell with FDA-compliant oil -10 ... +100 °C (14 ... +212 °F)

Ambient conditions

- Ambient temperature/enclosure Observe the temperature class in areas subject to explosion hazard.
 - Measuring cell with silicone oil filling -40 ... +85 °C (-40 ... +185 °F)
 - Measuring cell with inert oil for gauge pressure measuring cells: -40 ... +85 °C (-40 ... +185 °F)
 - 1 bar/100 kPa/3.6 psi
 - 4 bar/400 kPa/58 psi
 - 16 bar/1.6 MPa/232 psi
 - 63 bar/6.3 MPa/914 psi
 - Measuring cell with inert oil -20 ... +85 °C (-4 ... +185 °F)
 - Measuring cell with FDA-compliant oil -10 ... +85 °C (14 ... +185 °F)
 - Display -20 ... +80 °C (-4 ... +176 °F)
- Storage temperature -50 ... +85 °C (-58 ... +185 °F) (with FDA-compliant oil: -20 ... + 85 °C (-4 ... +185 °F))
- Climatic class in accordance with IEC 60721-3-4 4K4H
- Degree of protection
 - According to IEC 60529 IP66, IP68
 - According to NEMA 250 Type 4X
- Electromagnetic compatibility
 - Emitted interference and interference immunity According to IEC 61326 and NAMUR NE 21

Design

Weight

Approx. 2.3 kg (5.07 lb) with aluminum enclosure
Approx. 4.2 kg (9.25 lb) for stainless steel enclosure

Material

- Wetted parts materials
 - Process connection Stainless steel, material no. 1.4404/316L or Alloy C22, material no. 2.4602
 - Oval flange Stainless steel, mat. no. 1.4404/316L
 - Seal diaphragm Stainless steel, material no. 1.4404/316L or Alloy C276, material no. 2.4819
- Non-wetted parts materials
 - Electronics housing
 - Low-copper die-cast aluminum GD-AlSi 12 or stainless steel precision casting, mat. no. 1.4409/ CF-3M
 - Standard: Powder coating with polyurethane
 - Option: 2 coats: Coat 1: epoxy-based; coat 2: Polyurethane
 - Stainless steel type plate (1.4404/316L)
 - Mounting bracket Electrogalvanized steel or stainless steel

Process connection

- Connection shank G1/2A according to DIN EN 837-1
- Female thread ½-14 NPT
- Male thread M20 x 1.5 and ½-14 NPT
- Oval flange (PN 160 (MWP 2320 psi g)) with fastening screw thread:
- Oval flange (PN 420 (MWP 2320 psi g)) with fastening screw thread:
 - 7/16-20 UNF according to EN 61518
 - M10 according to DIN 19213
- Oval flange (PN 420 (MWP 2320 psi g)) with fastening screw thread:
 - 7/16-20 UNF according to EN 61518
 - M12 according to DIN 19213
- Male thread M20 x 1.5 and ½-14 NPT

Electrical connection

- Cable entry via the following screwed glands:
- M20 x 1.5
 - ½-14 NPT
 - Han 7D/Han 8D device plug¹⁾
 - M12 device plug

Displays and controls

Keys

4 keys for operation directly on the device

Display

- With or without integrated display (optional)
- Cover with inspection window (optional)

Pressure Measurement

Transmitters for applications with advanced requirements (Advanced)

SITRANS P320/P420

for gauge pressure (pressure series)

SITRANS P320 / SITRANS P420 for gauge pressure (pressure series)

Auxiliary power U_H

Terminal voltage on pressure transmitter	10.5 ... 45 V DC 10.5 ... 30 V DC in intrinsically safe mode
Ripple	$U_{SS} \leq 0.2 \text{ V}$ (47 ... 125 Hz)
Noise	$U_{\text{eff}} \leq 1.2 \text{ mV}$ (0.5 ... 10 kHz)
Auxiliary power	–
Separate supply voltage	–

Certificates and approvals

Classification according to pressure equipment directive (PED 2014/68/EU)	For gases of fluid group 1 and liquids of fluid group 1; complies with requirements of article 4, paragraph 3 (sound engineering practice)
Drinking water	
• WRAS (England)	Available soon
• ACS (France)	Available soon
• DVGW (Germany)	Available soon
• NSF (USA)	Available soon
CRN (Canada)	Available soon
Explosion protection acc. to NEPSI (China)	Available soon
Explosion protection acc. to INMETRO (Brazil)	Available soon
BAM (Germany), oxygen expenditures	Available soon
Explosion protection	
• Intrinsic safety "i"	
- Marking	II 1/2 G Ex ia/ib IIC T4/T6 Ga/Gb
- Permissible ambient temperature	-40 ... +80 °C (-40 ... +176 °F) temperature class T4 -40 ... +70 °C (-40 ... +158 °F) temperature class T6
- Permissible temperature of measuring medium	-40 ... +100 °C (-40 ... +212 °F) temperature class T4 -40 ... +70 °C (-40 ... +158 °F) temperature class T6
- Connection	To certified intrinsically safe circuits with peak values: $U_i = 30 \text{ V}$, $I_i = 101 \text{ mA}$, $P_i = 760 \text{ mW}$ $U_i = 29 \text{ V}$, $I_i = 110 \text{ mA}$, $P_i = 800 \text{ mW}$ $L_i = 0.24 \text{ } \mu\text{H/C}_i = 3.29 \text{ nF}$
- Effective internal inductance/capacitance	
• Flameproof enclosure "d"	
- Marking	Ex II 1/2 G Ex ia/db IIC T4/T6 Ga/Gb
- Permissible ambient temperature	-40 ... +80 °C (-40 ... +176 °F) temperature class T4 -40 ... +70 °C (-40 ... +158 °F) temperature class T6
- Permissible temperature of measuring medium	-40 ... +100 °C (-40 ... +212 °F) temperature class T4 -40 ... +70 °C (-40 ... +158 °F) temperature class T6
- Connection	To a circuit with the operating values: $U_n = 10.5 \text{ to } 45 \text{ V}$, $4 \text{ ... } 20 \text{ mA}$
• Dust explosion protection for Zone 20, 21, 22	
- Marking	Ex II 1D Ex tb IIIC T120 °C Da Ex II 2D Ex tb IIIC T120 °C Db Ex II 3D Ex tc IIIC T120 °C Dc
- Permissible ambient temperature	-40 ... +80 °C (-40 ... +176 °F)
- Permissible temperature of measuring medium	-40 ... +100 °C (-40 ... +212 °F)
- Max. surface temperature	120 °C (248 °F)
- Connection	To a circuit with the operating values: $U_n = 10.5 \text{ to } 45 \text{ V}$, $4 \text{ ... } 20 \text{ mA}$
• Dust explosion protection for Zone 20, 21, 22	
- Marking	Ex II 1D Ex ia IIIC T120 °C Da Ex II 2D Ex ib IIIC T120 °C Db Ex II 3D Ex ic IIIC T120 °C Dc
- Permissible ambient temperature	-40 ... +80 °C (-40 ... +176 °F)
- Permissible temperature of measuring medium	-40 ... +100 °C (-40 ... +212 °F)
- Connection	To certified intrinsically safe circuits with the peak values: $U_i = 30 \text{ V}$, $I_i = 101 \text{ mA}$, $P_i = 760 \text{ mW}$ $U_i = 29 \text{ V}$, $I_i = 110 \text{ mA}$, $P_i = 800 \text{ mW}$ $L_i = 0.24 \text{ } \mu\text{H/C}_i = 3.29 \text{ nF}$
- Effective internal inductance/capacitance	

Pressure Measurement

Transmitters for applications with advanced requirements (Advanced)

SITRANS P320/P420

for gauge pressure (pressure series)

1

SITRANS P320 / SITRANS P420 for gauge pressure (pressure series)

• Type of protection for Zone 2	Ex II 3G Ex ec IIC T4/T6 Gc
- Marking	Ex II 3G Ex ic IIC T4/T6 Gc
- Permissible ambient temperature "ec"	-40 ... +80 °C (-40 ... +176 °F) temperature class T4 -40 ... +40 °C (-40 ... +104 °F) temperature class T6
- Permissible ambient temperature "ic"	-40 ... +80 °C (-40 ... +176 °F) temperature class T4 -40 ... +80 °C (-40 ... +176 °F) temperature class T6
- Permissible temperature of measuring medium	-40 ... +100 °C (-40 ... +212 °F) temperature class T4 -40 ... +70 °C (-40 ... +158 °F) temperature class T6
- "ec" connection	To a circuit with the operating values: $U_n = 10.5$ to 30 V, 4 ... 20 mA
- "ic" connection	To certified intrinsically safe circuits with the peak values: $U_i = 30$ V, $I_i = 101$ mA, $P_i = 760$ mW $U_i = 29$ V, $I_i = 110$ mA, $P_i = 800$ mW
	Effective internal inductance/capacitance: $L_i = 0.24$ μ H/ $C_i = 3.29$ nF
• Explosion protection acc. to FM	Available soon
- Marking (XP/DIP) or IS; NI; S	CL I, DIV 1, GP ABCD T4 ... T6; CL II, DIV 1, GP EFG; CL III; Ex ia IIC T4 ... T6; CL I, DIV 2, GP ABCD T4 ... T6; CL II, DIV 2, GP FG; CL III
• Explosion protection according to CSA	Available soon
- Marking (XP/DIP) or (IS)	CL I, DIV 1, GP ABCD T4 ... T6; CL II, DIV 1, GP EFG; CL III; Ex ia IIC T4 ... T6; CL I, DIV 2, GP ABCD T4 ... T6; CL II, DIV 2, GP FG; CL III

1) Han 8D is identical to Han 8U.

HART communication

HART	230 ... 1100 Ω
Protocol	HART 7
Software for computer	SIMATIC PDM

Pressure Measurement

Transmitters for applications with advanced requirements (Advanced)

SITRANS P320/P420

for gauge pressure (pressure series)

1

Selection and ordering data

	Article No.
Pressure transmitters for gauge pressure (pressure series)	
SITRANS P320	7MF030 - - - - -
SITRANS P420	7MF040 - - - - -
Click on the Article no. for the online configuration in the PIA Life Cycle Portal.	
Communication	
HART, 4 ... 20 mA	0
Measuring cell filling	
Silicone oil	1
Inert liquid	3
Neobee oil	4
Maximum measuring span	
250 mbar (3.6 psi)	F
1000 mbar (14.5 psi)	J
4000 mbar (58 psi)	N
16 bar (232 psi)	Q
63 bar (914 psi)	T
160 bar (2321 psi)	V
400 bar (5802 psi)	W
700 bar (10153 psi)	X
Process connection	
Male thread M20 x 1.5	B
Male thread G½ (DIN EN 837-1)	D
Female thread ½-14 NPT	E
Male thread ½-14 NPT	F
Oval flange, mounting thread: 7/16-20 UNF (IEC 61518)	G
Oval flange, mounting thread: M10 (DIN 19213)	H
Oval flange, mounting thread: M12 (DIN 19213)	J
Version for diaphragm seal pressure	U
Wetted parts materials: Process connection, seal diaphragm	
Stainless steel 316L/1.4404, stainless steel 316L/1.4404	0
Stainless steel 316L/1.4404, alloy C276/2.4819	1
Alloy C22/2.4602, alloy C276/2.4819	2
Non-wetted parts materials	
Die-cast aluminum	1
Stainless steel precision casting CF3M/1.4409 similar to 316L	2
Enclosure	
Dual chamber device	5
Type of protection	
Without Ex	A
Intrinsic safety	B
Flameproof enclosure	C
Flameproof enclosure, intrinsic safety	D
Dust protection by enclosure Zone 21/22 (DIP), increased safety Zone 2	L
Dust protection by enclosure Zone 20/21/22 (DIP), increased safety Zone 2	M
Combination of options B, C and L (zone model)	S
Combination of options B, C and M (zone model, Class Division)	T
Electrical connections/cable entries	
Thread for cable gland	
• 2 x M20 x 1.5	F
• 2 x ½-14 NPT	M
Local operation/display	
Without display (cover closed)	0
With display (cover closed)	1
With display (cover with glass pane)	2

Pressure Measurement

Transmitters for applications with advanced requirements (Advanced)

SITRANS P320/P420

for gauge pressure (pressure series)

1

Selection and ordering data

<i>Options</i>	Order code	<i>Options</i>	Order code
Add "-Z" to article no. and specify order code.		Device options	
Cable glands included		PDF file with device settings	D10
Plastic	A00	Double layer coating (epoxy resin and polyurethane) 120 µm of enclosure and cover	D20
Metal	A01	FVMQ enclosure sealing	D21
Stainless steel	A02	IP66/IP68 degree of protection (not for M12 and Han device plugs)	D30
Stainless steel 316L/1.4404	A03	TAG label empty	D40
CMP, for XP devices	A10	Without labeling of the measuring range on the TAG label	D41
CAPRI ADE 4F, CuZn, cable inner diameter 7 ... 12 mm, cable outer diameter 10 ... 16 mm	A11	Stainless steel Ex plate 1.4404/316L	D42
CAPRI ADE 4F, stainless steel, cable inner diameter 7 ... 12 mm, cable outer diameter 10 ... 16 mm	A12	Increase of pressure stage from PN 420 to PN 500	D50
Han device plug mounted left		Overvoltage protection up to 6 kV (external)	D71
Han 7D device plug (plastic, straight)	A30	Adhesive labels on transport packaging (supplied by customer)	D90
Han 7D device plug (plastic, angled)	A31		
Han 7D device plug (metal, straight)	A32	General approval without Ex approval	
Han 7D device plug (metal, angled)	A33	Worldwide (CE, RCM) except EAC, FM, CSA, KCC	E00
Han 8D device plug (plastic, straight)	A34	Worldwide (CE, RCM, EAC, FM, CSA, KCC)	E01
Han 8D device plug (plastic, angled)	A35	CSA	E06
Han 8D device plug (metal, straight)	A36	EAC	E07
Han 8D device plug (metal, angled)	A37	FM	E08
Cable socket included		KCC	E09
Plastic, for Han 7D/8D device plugs	A40	UL	E10
Metal, for Han 7D/8D device plugs	A41	Explosion protection approvals	
M12 device plug mounted left		ATEX (Europe)	E20
Stainless steel, without cable socket	A62	CSA (USA and Canada)	E21
Stainless steel, with cable socket	A63	FM (USA and Canada)	E22
Cable entry/connector mounting		IECEX (Worldwide)	E23
2x sealing plugs M20 x 1.5, IP66/68 installed on both sides	A90	EACEx (GOST-R, -K, -B)	E24
2x sealing plugs ½-14 NPT, IP66/68 installed on both sides	A91	INMETRO (Brazil)	E25
Cable gland/connector mounted left	A97	KCs (Korea)	E26
Cable gland/connector mounted on right	A99	NEPSI (China)	E27
Nameplate labeling		PESO (India)	E28
German (bar)	B11	TIIS Hazardous (Japan)	E29
French (bar)	B12	UKR Sepro (Ukraine)	E30
Spanish (bar)	B13	ATEX (Europe) and IECEX (Worldwide)	E47
Italian (bar)	B14	CSA (Canada) and FM (USA)	E48
Chinese (bar)	B15	ATEX (Europe) and IECEX (Worldwide) + CSA (Canada) and FM (USA)	E49
Russian (bar)	B16	Marine approvals	
English (psi)	B20	DNV-GL (Det Norske Veritas/Germanischer Lloyd)	E50
Chinese (Pa)	B35	LR (Lloyds Register)	E51
Certificates		BV (Bureau Veritas)	E52
Quality test certificate, 5-point factory calibration (IEC 60770-2)	C11	ABS (American Bureau of Shipping)	E53
Acceptance certificate (EN 10204-3.1) - Material of pressurized and wetted parts	C12	KR (Korean Register of Shipping)	E56
Test report - NACE (MR 0103-2012 and MR 0175-2009)	C13	RINA (Registro Italiano Navale)	E57
Test report (EN 10204-2.2) - Wetted parts	C14	CCS (China Classification Society)	E58
Acceptance certificate (EN 10204-3.1) - PMI test of pressurized and wetted parts	C15	Country-specific approvals	
Certificates for functional safety		CRN approval Canada (Canadian Registration Number)	E60
Functional safety (IEC 61508) - SIL2/3	C20	Special approvals	
		Oxygen application (with inert liquid, max. 100 bar (1 450 psi) at 60° C (140 °F))	E80
		Dual seal	E81
		WRC / WRAS (drinking water); only with pressure cap O-rings made of EPDM	E83
		NSF61 (drinking water)	E84
		ACS (drinking water)	E85

Pressure Measurement

Transmitters for applications with advanced requirements (Advanced)

SITRANS P320/P420

for gauge pressure (pressure series)

Options	Order code
Mounting bracket	
Steel, galvanized	H01
Stainless steel 1.4301/304	H02
Stainless steel 1.4404/316L	H03
Flange connections with flange EN 1092-1	
With flange adapter G½ Form B1	
• DN 25 PN 40, stainless steel 1.4571/316Ti	J80
• DN 50 PN 40, stainless steel 1.4571/316Ti	J81
• DN 80 PN 40, stainless steel 1.4571/316Ti	J82
With siphon G½ Form B1	
• DN 25 PN 40, stainless steel 1.4571/316Ti	J83
• DN 50 PN 40, stainless steel 1.4571/316Ti	J84
• DN 80 PN 40, stainless steel 1.4571/316Ti	J85
• DN 25 PN 100, stainless steel 1.4571/316Ti	J86
Process flanges, gaskets (instead of standard gaskets FKM (FPM))	
Seal (EN 837-1) material Fe (soft iron)	K60
Seal (EN 837-1) material 1.4571	K61
Seal (EN 837-1) material Cu	K62
Process connection	
Process connection male thread G½, bore hole 11 mm	K80
Shut-off valves, pneumatic blocks	
With mounted pneumatic block 7MF9011-4EA, process connection at transmitter G½ shank, PTFE sealing ring and pressure test certified in test report (EN 10204-2.2)	T02
With mounted pneumatic block 7MF9011-4FA, process connection at transmitter female thread ½-14 NPT, sealing tape. With PTFE sealing ring and pressure test certified in test report (EN 10204-2.2)	T03
With mounted pneumatic block 7MF9411-5AA, process connection at transmitter oval flange with PTFE gasket, steel mounting screws, pressure test certified in test report (EN 10204-2.2)	T05
With mounted pneumatic block 7MF9411-5AA, process connection at transmitter oval flange with PTFE gasket, stainless steel mounting screws, pressure test certified in test report (EN 10204-2.2)	T06

Selection and ordering data

Customer-specific device settings	Order code
Add "-Z" to article no., specify order code and plain text or drop-down list selection.	
Measuring span Start of scale value (max. 5 characters), full scale value (max. 5 characters), unit [mbar, bar, kPa, MPa, psi, ...], example: -0.5 ... 10.5 psi	Y01
Input field 1 and input field 2: max. 5 characters and numbers only; decimal places as dot (comma is automatically converted to dot).	
Drop-down list: Pa, MPa, kPa, hPa, bar, mbar, psi, g/cm ² , kg/cm ² , kgf/cm ² , inH ₂ O, inH ₂ O (4°C), ftH ₂ O, mmH ₂ O, mmH ₂ O (4°C), mH ₂ O (4°C), mmHg, inHg, atm, torr	
TAG (on stainless steel plate and device parameters, max. 32 characters)	Y15
Input field: Free text, max. 32 characters	
Measuring point description (on stainless steel plate and device parameters, max. 32 characters)	Y16
Input field: Free text, max. 32 characters	
TAG short (device parameters, max. 8 characters)	Y17
Input field: Free text, max. 8 characters	
Local display [Pressure, Percent], reference [None, Absolute, Relative], example: Pressure gauge	Y21
Drop-down list: Percent, pressure unit, pressure unit abs., pressure unit gauge	
Local display Scaling with standard units [m³/s, l/s, m, inch, ...], example 1 ... 5 m	Y22
Input field 1 and input field 2: max. 5 characters and numbers only; decimal places as dot (comma is automatically converted to dot).	
Drop-down list: m, cm, mm, in, ft, m ³ , l, hl, in ³ , ft ³ , yd ³ , gal, gal (UK), bu, bbl, bbl (US), SCF, Nm ³ , NI.	
Local display Scaling with user-specific units (max. 12 characters), example 1 ... 5 m	Y23
Input field 1 and input field 2: max. 5 characters and numbers only; decimal places as dot (comma is automatically converted to dot).	
Input field 3: Free text, max. 8 characters	
Saturation limits instead of 3.8 ... 20.5 mA, example: 3.8 ... 22.0 mA	Y30
Drop-down list 1: 3.9, 4	
Drop-down list 2: 20.8, 22	
Fault current instead of 3.6 mA [22.5 mA, 22.8 mA]	Y31
Drop-down list: 3.75; 21.75; 22.5; 22.6	
Damping in seconds instead of 2 s (0.0 ... 100.0 s)	Y32
Input field: max. 4 characters and numbers only; decimal places as dot (comma is automatically converted to dot); min. value = 0; max. value = 100.	
ID number of special version	Y99
Input field: max. 4 characters and only natural numbers from 0 ... 9999	

Pressure Measurement

Transmitters for applications with advanced requirements (Advanced)

SITRANS P320/P420

for gauge pressure (pressure series)

1

Dimensional drawings

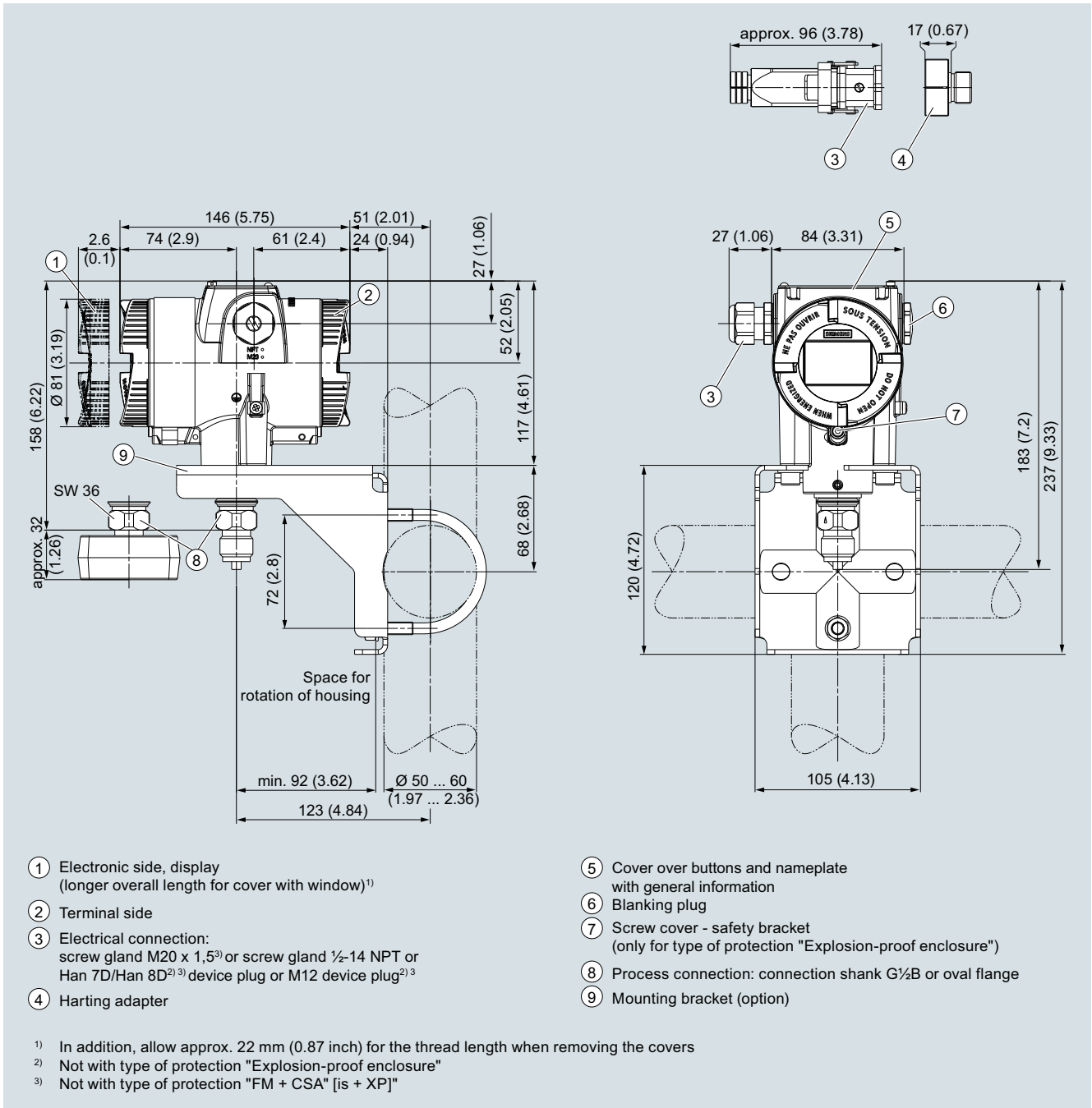

SITRANS P320/P420 pressure transmitter for gauge pressure (pressure series), dimensions in mm (inch)

Pressure Measurement

Transmitters for applications with advanced requirements (Advanced)

SITRANS P320/P420

for gauge pressure (differential pressure series)

Technical specifications

SITRANS P320 / SITRANS P420 for gauge pressure (differential pressure series)

Input

Measured variable	Gauge pressure		
Span (infinitely adjustable) and maximum operating pressure (pursuant to Pressure Equipment Directive 2014/68/EU)	Span	Max. permissible operating pressure MAWP (PS)	Maximum permissible test pressure
	1 ... 20 mbar	160 bar	160 bar
	0.1 ... 2 kPa	16 MPa	16 MPa
	0.4019 ... 8.037 inH ₂ O	2320 psi	2320 psi
	1 ... 60 mbar	160 bar	160 bar
	0.1 ... 6 kPa	16 MPa	16 MPa
	0.4019 ... 24.11 inH ₂ O	2320 psi	2320 psi
	2.5 ... 250 mbar	160 bar	160 bar
	0.2 ... 25 kPa	16 MPa	16 MPa
	1.005 ... 100.5 inH ₂ O	2320 psi	2320 psi
	6 ... 600 mbar	160 bar	160 bar
	0.6 ... 60 kPa	16 MPa	16 MPa
	2.41 ... 241.1 inH ₂ O	2320 psi	2320 psi
	16 ... 1600 mbar	160 bar	160 bar
	1.6 ... 160 kPa	16 MPa	16 MPa
	6.43 ... 643 inH ₂ O	2320 psi	2320 psi
	50 ... 5000 mbar	160 bar	160 bar
	5 ... 500 kPa	16 MPa	16 MPa
	20.09 ... 2009 inH ₂ O	2320 psi	2320 psi
	0.3 ... 30 bar	160 bar	160 bar
	0.03 ... 3 MPa	16 MPa	16 MPa
	4.35 ... 435 psi	2320 psi	2320 psi
Measuring limits			
• Low measuring limit			
- Measuring cell with silicone oil filling	30 mbar a/3 kPa a/0.44 psi a		
- Measuring cell with inert oil	30 mbar a/3 kPa a/0.44 psi a		
- Measuring cell with FDA-compliant oil	100 mbar a/10 kPa a/1.45 psi a		
• Upper measuring limit	100% of the max. measuring span (for oxygen measurement max. 100 bar/10 MPa/ 1450 psi and 60 °C (140 °F) ambient temperature/process temperature)		
• Start of scale	Between the measuring limits (infinitely adjustable)		

Output

	HART
Output signal	4 ... 20 mA
• Low saturation limit (infinitely adjustable)	3.55 mA, factory preset to 3.8 mA
• High saturation limit (infinitely adjustable)	22.8 mA, factory-set to 20.5 mA or optionally 22.0 mA
• Ripple (without HART communication)	$I_{pp} \leq 0.5\%$ of max. output current
Adjustable damping	0 ... 100 s, continuously adjustable over remote operation
	0 ... 100 s, in increments of 0.1 s, adjustable over display
• Current transmitter	3.55 ... 22.8 mA
• Failure signal	3.55 ... 22.8 mA
Load	Resistor R [Ω]
• Without HART communication	$R = (U_H - 10.5 \text{ V})/22.8 \text{ mA}$, U_H : Power supply in V
• With HART communication	$R = 230 \dots 1100 \Omega$ (HART communicator (handheld)) $R = 230 \dots 500 \Omega$ (SIMATIC PDM)
Characteristic curve	<ul style="list-style-type: none"> • Linearly increasing or linearly decreasing • Linear increase or decrease or according to the square root (only for differential pressure and flow)
Physical bus	-
Polarity-independent	-

Pressure Measurement

Transmitters for applications with advanced requirements (Advanced)

SITRANS P320/P420

for gauge pressure (differential pressure series)

1

SITRANS P320 / SITRANS P420 for gauge pressure (differential pressure series)
Measuring accuracy

Reference conditions

- According to EN 60770-1
- Rising characteristic curve
- Start of scale value 0 bar/kPa/psi
- Seal diaphragm stainless steel
- Measuring cell with silicone oil filling
- Room temperature 25 °C (77 °F)

Conformity error at limit point setting, including hysteresis and repeatability

Measuring span ratio r (spread, Turn-Down) $r = \text{max. measuring span/set measuring span and nominal measuring range}$

• Linear characteristic

- 20 mbar/2 kPa/8.031 inH₂O

$r \leq 5:$	$\leq 0.075\%$	
$5 < r \leq 20:$	$\leq (0.005 \cdot r + 0.05)\%$	

- 60 mbar/6 kPa/24.09 inH₂O

$r \leq 5:$	$\leq 0.075\%$	
$5 < r \leq 60:$	$\leq (0.005 \cdot r + 0.05)\%$	

- 250 mbar/25 kPa/3.6 psi
 600 mbar/60 kPa/240.9 inH₂O
 1600 mbar/160 kPa/642.4 inH₂O
 5000 mbar/500 kPa/2008 inH₂O
 30 bar/3 MPa/435 psi

$r \leq 5:$	$\leq 0.065\%$ (SITRANS P320)	
$5 < r \leq 100:$	$\leq 0.04\%$ (SITRANS P420)	
	$\leq (0.005 \cdot r + 0.045)\%$ (SITRANS P320)	
	$\leq (0.004 \cdot r + 0.045)\%$ (SITRANS P420)	

Influence of ambient temperature as % per 28 °C (50 °F)

- 20 mbar/2 kPa/8.031 inH₂O $\leq (0.15 \cdot r + 0.1)\%$ - 60 mbar/6 kPa/24.09 inH₂O $\leq (0.075 \cdot r + 0.1)\%$

- 250 mbar/25 kPa/3.6 psi
 600 mbar/60 kPa/240.9 inH₂O
 1600 mbar/160 kPa/642.4 inH₂O
 5000 mbar/500 kPa/2008 inH₂O
 30 bar/3 MPa/435 psi

 $\leq (0.025 \cdot r + 0.125)\%$ (SITRANS P320)

- 250 mbar/25 kPa/3.6 psi
 5000 mbar/500 kPa/2008 inH₂O

 $\leq (0.025 \cdot r + 0.625)\%$ (SITRANS P420)

- 600 mbar/60 kPa/240.9 inH₂O
 1600 mbar/160 kPa/642.4 inH₂O
 30 bar/3 MPa/435 psi

 $\leq (0.0125 \cdot r + 0.625)\%$ (SITRANS P420)Long-term stability at ± 30 °C (± 54 °F)- 20 mbar/2 kPa/8.031 inH₂O $\leq (0.2 \cdot r)\%$ per year- 60 mbar/6 kPa/24.09 inH₂OIn 5 years $\leq (0.25 \cdot r)\%$

- 250 mbar/25 kPa/3.6 psi

In 5 years $\leq (0.125 \cdot r)\%$

600 mbar/60 kPa/240.9 inH₂O
 1600 mbar/160 kPa/642.4 inH₂O
 5000 mbar/500 kPa/2008 inH₂O

In 10 years $\leq (0.15 \cdot r)\%$

• 30 bar/3 MPa/435 psi

In 5 years $\leq (0.25 \cdot r)\%$ In 10 years $\leq (0.35 \cdot r)\%$ Step response time T_{63} (without electrical damping)

Approx. 0.1 s

Effect of mounting position (in pressure per change of angle)

 ≤ 0.07 mbar/0.007 kPa/0.01015266 psi per 10° incline (zero-point correction is possible with position error compensation)

Effect of auxiliary power (in % per voltage change)

0.005% per 1 V

Rated conditions

Temperature of medium

- Measuring cell with silicone oil filling
 - Measuring cell 30 bar (435 psi), PN 420
- Measuring cell with inert oil
 - Measuring cell 30 bar (435 psi), PN 420
- Measuring cell with FDA-compliant oil
- In conjunction with dust explosion protection

-40 ... +100 °C (-40 ... +212 °F)

-20 ... +85 °C (-4 ... +185 °F)

-20 ... +100 °C (-4 ... +212 °F)

-20 ... +85 °C (-4 ... +185 °F)

-10 ... +100 °C (14 ... +212 °F)

-40 ... +85 °C (-4 ... +185 °F)

Ambient conditions

- Ambient temperature/enclosure
 - Measuring cell with silicone oil filling
 - Measuring cell with silicone oil filling, measuring cell 30 bar (435 psi), PN 420
 - Measuring cell with inert oil
 - Measuring cell with FDA-compliant oil
 - Display
- Storage temperature
- Climatic class in accordance with IEC 60721-3-4
- Degree of protection
 - According to IEC 60529
 - According to NEMA 250
- Electromagnetic compatibility
 - Emitted interference and interference immunity

Observe the temperature class in areas subject to explosion hazard.

-40 ... +85 °C (-40 ... +185 °F)

-20 ... +85 °C (-4 ... +185 °F)

-20 ... +85 °C (-4 ... +185 °F)

-10 ... +85 °C (14 ... +185 °F)

-20 ... +80 °C (-4 ... +176 °F)

-50 ... +85 °C (-58 ... +185 °F); with FDA-compliant oil: -20 ... +85 °C (-4 ... +185 °F)

4K4H

IP66, IP68

Type 4X

According to IEC 61326 and NAMUR NE 21

Pressure Measurement

Transmitters for applications with advanced requirements (Advanced)
SITRANS P320/P420

for gauge pressure (differential pressure series)

SITRANS P320 / SITRANS P420 for gauge pressure (differential pressure series)

Design

Weight	Approx. 3.9 kg (8.5 lb) with aluminum enclosure Approx. 5.8 kg (12.7 lb) with stainless steel enclosure
Material	
• Wetted parts materials	
- Seal diaphragm	Stainless steel, mat. no. 1.4404/316L, Alloy C276, mat. no. 2.4819, Monel, mat. no. 2.4360, tantalum or gold
- Process flanges and sealing plugs	Stainless steel, mat. no. 1.4408 to PN 160, mat. no. 1.4571/316Ti for PN 420, Alloy C22, 2.4602 or Monel, mat. no. 2.4360
- O-ring	FPM (Viton) or optionally: PTFE, FEP, FEPM and NBR
• Non-wetted parts materials	
- Electronics housing	<ul style="list-style-type: none"> • Low-copper die-cast aluminum GD-AISi 12 or stainless steel precision casting, mat. no. 1.4409/ CF-3M • Standard: Powder coating with polyurethane Option: 2 coats: Coat 1: epoxy-based; coat 2: Polyurethane • Stainless steel type plate (1.4404/316L)
- Pressure flange screws	Stainless steel ISO 3506-1 A4-70
- Mounting bracket	Steel, electrogalvanized steel, or stainless steel
Process connection	½-18 NPT female thread and flat connection with 7/16-20 UNF fastening screw thread in accordance with EN 61518 or M10 fastening screw thread in accordance with DIN 19213 (M12 for PN 420 (MWP 6092 psi))
Electrical connection	<p>Screw terminals</p> <p>Cable entry via the following screwed glands:</p> <ul style="list-style-type: none"> • M20 x 1.5 • ½-14 NPT • Han 7D/Han 8D device plug¹⁾ • M12 device plug

Displays and controls

Keys	4 keys for operation directly on the device
Display	<ul style="list-style-type: none"> • With or without integrated display (optional) • Cover with inspection window (optional)

Auxiliary power U_H

Terminal voltage on pressure transmitter	10.5 ... 45 V DC 10.5 ... 30 V DC in intrinsically safe mode
Ripple	$U_{SS} \leq 0.2 \text{ V}$ (47 ... 125 Hz)
Noise	$U_{eff} \leq 1.2 \text{ mV}$ (0.5 ... 10 kHz)
Auxiliary power	–
Separate supply voltage	–

Certificates and approvals

Classification according to pressure equipment directive (PED 2014/68/EU)	For gases of fluid group 1 and liquids of fluid group 1; complies with requirements of article 4, paragraph 3 (sound engineering practice)
Drinking water	
• WRAS (England)	Available soon
• ACS (France)	Available soon
• DVGW (Germany)	Available soon
• NSF (USA)	Available soon
CRN (Canada)	Available soon
Explosion protection acc. to NEPSI (China)	Available soon
Explosion protection acc. to INMETRO (Brazil)	Available soon
BAM (Germany), oxygen expenditures	Available soon
Explosion protection	
• Intrinsic safety "i"	
- Marking	II 1/2 G Ex ia/ib IIC T4/T6 Ga/Gb
- Permissible ambient temperature	-40 ... +80 °C (-40 ... +176 °F) temperature class T4 -40 ... +70 °C (-40 ... +158 °F) temperature class T6
- Permissible temperature of measuring medium	-40 ... +100 °C (-40 ... +212 °F) temperature class T4 -40 ... +70 °C (-40 ... +158 °F) temperature class T6
- Connection	To certified intrinsically safe circuits with the peak values: $U_i = 30 \text{ V}$, $I_i = 101 \text{ mA}$, $P_i = 760 \text{ mW}$ $U_i = 29 \text{ V}$, $I_i = 110 \text{ mA}$, $P_i = 800 \text{ mW}$ $L_i = 0.24 \mu\text{H}/C_i = 3.29 \text{ nF}$
- Effective internal inductance/capacitance	
• Flameproof enclosure "d"	
- Marking	Ex II 1/2 G Ex ia/db IIC T4/T6 Ga/Gb
- Permissible ambient temperature	-40 ... +80 °C (-40 ... +176 °F) temperature class T4 -40 ... +70 °C (-40 ... +158 °F) temperature class T6
- Permissible temperature of measuring medium	-40 ... +100 °C (-40 ... +212 °F) temperature class T4 -40 ... +70 °C (-40 ... +158 °F) temperature class T6
- Connection	To a circuit with the operating values: $U_n = 10.5 \text{ to } 45 \text{ V}$, $4 \text{ ... } 20 \text{ mA}$

Pressure Measurement

Transmitters for applications with advanced requirements (Advanced)

SITRANS P320/P420

for gauge pressure (differential pressure series)

1

SITRANS P320 / SITRANS P420 for gauge pressure (differential pressure series)

<ul style="list-style-type: none"> • Dust explosion protection for Zone 20, 21, 22 <ul style="list-style-type: none"> - Marking - Permissible ambient temperature - Permissible temperature of measuring medium - Max. surface temperature - Connection • Dust explosion protection for Zone 20, 21, 22 <ul style="list-style-type: none"> - Marking - Permissible ambient temperature - Permissible temperature of measuring medium - Connection - Effective internal inductance/capacitance • Type of protection for Zone 2 <ul style="list-style-type: none"> - Marking - Permissible ambient temperature "ec" - Permissible ambient temperature "ic" - Permissible temperature of measuring medium - "ec" connection - "ic" connection • Explosion protection acc. to FM <ul style="list-style-type: none"> - Marking (XP/DIP) or IS; NI; S • Explosion protection according to CSA <ul style="list-style-type: none"> - Marking (XP/DIP) or (IS) 	<p>Ex II 1D Ex tb IIIC T120 °C Da Ex II 2D Ex tb IIIC T120 °C Db Ex II 3D Ex tc IIIC T120 °C Dc</p> <p>-40 ... +80 °C (-40 ... +176 °F) -40 ... +100 °C (-40 ... +212 °F) 120 °C (248 °F)</p> <p>To a circuit with the operating values: $U_n = 10.5$ to 45 V, 4 ... 20 mA</p> <p>Ex II 1D Ex ia IIIC T120 °C Da Ex II 2D Ex ib IIIC T120 °C Db Ex II 3D Ex ic IIIC T120 °C Dc</p> <p>-40 ... +80 °C (-40 ... +176 °F) -40 ... +100 °C (-40 ... +212 °F)</p> <p>To certified intrinsically safe circuits with the peak values: $U_i = 30$ V, $I_i = 101$ mA, $P_i = 760$ mW $U_i = 29$ V, $I_i = 110$ mA, $P_i = 800$ mW $L_i = 0.24$ μH/$C_i = 3.29$ nF</p> <p>Ex II 3G Ex ec IIC T4/T6 Gc Ex II 3G Ex ic IIC T4/T6 Gc</p> <p>-40 ... +80 °C (-40 ... +176 °F) temperature class T4 -40 ... +40 °C (-40 ... +104 °F) temperature class T6 -40 ... +80 °C (-40 ... +176 °F) temperature class T4 -40 ... +80 °C (-40 ... +176 °F) temperature class T6 -40 ... +100 °C (-40 ... +212 °F) temperature class T4 -40 ... +70 °C (-40 ... +158 °F) temperature class T6</p> <p>To a circuit with the operating values: $U_n = 10.5$ to 30 V, 4 ... 20 mA</p> <p>To certified intrinsically safe circuits with the peak values: $U_i = 30$ V, $I_i = 101$ mA, $P_i = 760$ mW $U_i = 29$ V, $I_i = 110$ mA, $P_i = 800$ mW</p> <p>Effective internal inductance/capacitance: $L_i = 0.24$ μH/$C_i = 3.29$ nF</p> <p>Available soon CL I, DIV 1, GP ABCD T4 ... T6; CL II, DIV 1, GP EFG; CL III; Ex ia IIC T4 ... T6; CL I, DIV 2, GP ABCD T4 ... T6; CL II, DIV 2, GP FG; CL III</p> <p>Available soon CL I, DIV 1, GP ABCD T4 ... T6; CL II, DIV 1, GP EFG; CL III; Ex ia IIC T4 ... T6; CL I, DIV 2, GP ABCD T4 ... T6; CL II, DIV 2, GP FG; CL III</p>
---	--

1) Han 8D is identical to Han 8U.

HART communication

HART	230 ... 1100 Ω
Protocol	HART 7
Software for computer	SIMATIC PDM

Pressure Measurement

Transmitters for applications with advanced requirements (Advanced)

SITRANS P320/P420

for gauge pressure (differential pressure series)

1

Selection and ordering data

	Article No.
Pressure transmitters for gauge pressure (differential pressure series)	
SITRANS P320	7MF031 - - - - -
SITRANS P420	7MF041 - - - - -
Click on the Article no. for the online configuration in the PIA Life Cycle Portal.	
Communication	
HART, 4 ... 20 mA	0
Measuring cell filling	
Silicone oil	1
Inert liquid	3
Neobee oil	4
Maximum measuring span	
20 mbar (8.037 inH ₂ O)	B
60 mbar (24.11 inH ₂ O)	D
250 mbar (1005 inH ₂ O)	G
600 mbar (241.1 inH ₂ O)	H
1 600 mbar (643 inH ₂ O)	M
5000 mbar (2009 inH ₂ O)	P
30 bar (435 psi)	R
Process connection	
Oval flange, mounting thread: 7/16"-20 UNF (IEC 61518)	L
Oval flange, mounting thread: M10 (PN 160), (DIN 19213)	M
Oval flange, mounting thread: 7/16"-20 UNF (IEC 61518) with lateral ventilation	N
Oval flange, mounting thread: M10 (PN 160) (DIN 19213) with lateral ventilation	P
Wetted parts materials: Process connection, seal diaphragm	
Stainless steel 316L/1.4404, stainless steel 316L/1.4404	0
Stainless steel 316L/1.4404, alloy C276/2.4819	1
Alloy C22/2.4602, alloy C276/2.4819	2
Tantalum/tantalum (not in combination with maximum measuring span 20 mbar (0.29 psi) and 60 mbar (0.87 psi))	4
Monel 00/2.4360, Monel 400/2.4360 (not in combination with maximum measuring span 20 mbar (0.29 psi) and 60 mbar (0.87 psi))	6
Stainless steel 316L/1.4404, gold-plated (not in combination with maximum measuring span 20 mbar (0.29 psi) and 60 mbar (0.87 psi))	8
Non-wetted parts materials	
Die-cast aluminum	1
Stainless steel precision casting CF3M/1.4409 similar to 316L	2
Enclosure	
Dual chamber device	5
Type of protection	
Without Ex	A
Intrinsic safety	B
Flameproof enclosure	C
Flameproof enclosure, intrinsic safety	D
Dust protection by enclosure Zone 21/22 (DIP), increased safety Zone 2	L
Dust protection by enclosure Zone 20/21/22 (DIP), increased safety Zone 2	M
Combination of options B, C and L (zone model)	S
Combination of options B, C and M (zone model, Class Division)	T
Electrical connections/cable entries	
Thread for cable gland	
• 2 x M20 x 1.5	F
• 2 x 1/2"-14 NPT	M

	Article No.
Pressure transmitters for gauge pressure (differential pressure series)	
SITRANS P320	7MF 0 3 1 - [grid] - [grid]
SITRANS P420	7MF 0 4 1 - [grid] - [grid]
Local operation/display	
Without display (cover closed)	0
With display (cover closed)	1
With display (cover with glass pane)	2

Pressure Measurement

Transmitters for applications with advanced requirements (Advanced)

SITRANS P320/P420

for gauge pressure (differential pressure series)

1

Selection and ordering data

Options	Order code	Options	Order code
Add "-Z" to article no. and specify order code.			
Cable glands included		Device options	
Plastic	A00	PDF file with device settings	D10
Metal	A01	Double layer coating (epoxy resin and polyurethane) 120 µm of enclosure and cover	D20
Stainless steel	A02	FVMQ enclosure sealing	D21
Stainless steel 316L/1.4404	A03	IP66/IP68 degree of protection (not for M12 and Han device plugs)	D30
CMP, for XP devices	A10	TAG label empty	D40
CAPRI ADE 4F, CuZn, cable inner diameter 7 ... 12 mm, cable outer diameter 10 ... 16 mm	A11	Without labeling of the measuring range on the TAG label	D41
CAPRI ADE 4F, stainless steel, cable inner diameter 7 ... 12 mm, cable outer diameter 10 ... 16 mm	A12	Stainless steel Ex plate 1.4404/316L	D42
Han device plug mounted left		Increase of pressure stage from PN 420 to PN 500	D50
Han 7D device plug (plastic, straight)	A30	Overvoltage protection up to 6 kV (external)	D71
Han 7D device plug (plastic, angled)	A31	Adhesive labels on transport packaging (supplied by customer)	D90
Han 7D device plug (metal, straight)	A32		
Han 7D device plug (metal, angled)	A33	General approval without Ex approval	
Han 8D device plug (plastic, straight)	A34	Worldwide (CE, RCM) except EAC, FM, CSA, KCC	E00
Han 8D device plug (plastic, angled)	A35	Worldwide (CE, RCM, EAC, FM, CSA, KCC)	E01
Han 8D device plug (metal, straight)	A36	CSA	E06
Han 8D device plug (metal, angled)	A37	EAC	E07
Cable socket included		FM	E08
Plastic, for Han 7D/8D device plugs	A40	KCC	E09
Metal, for Han 7D/8D device plugs	A41	UL	E10
M12 device plug mounted left		Explosion protection approvals	
Stainless steel, without cable socket	A62	ATEX (Europe)	E20
Stainless steel, with cable socket	A63	CSA (USA and Canada)	E21
Cable entry/connector mounting		FM (USA and Canada)	E22
2x sealing plugs M20 x 1.5, IP66/68 installed on both sides	A90	IECEX (Worldwide)	E23
2x sealing plugs ½-14 NPT, IP66/68 installed on both sides	A91	EACEx (GOST-R, -K, -B)	E24
Cable gland/connector mounted left	A97	INMETRO (Brazil)	E25
Cable gland/connector mounted on right	A99	KCs (Korea)	E26
Nameplate labeling		NEPSI (China)	E27
German (bar)	B11	PESO (India)	E28
French (bar)	B12	TIIS Hazardous (Japan)	E29
Spanish (bar)	B13	UKR Sepro (Ukraine)	E30
Italian (bar)	B14	ATEX (Europe) and IECEX (Worldwide)	E47
Chinese (bar)	B15	CSA (Canada) and FM (USA)	E48
Russian (bar)	B16	ATEX (Europe) and IECEX (Worldwide) + CSA (Canada) and FM (USA)	E49
English (psi)	B20	Marine approvals	
Chinese (Pa)	B35	DNV-GL (Det Norske Veritas/Germanischer Lloyd)	E50
Certificates		LR (Lloyds Register)	E51
Quality test certificate, 5-point factory calibration (IEC 60770-2)	C11	BV (Bureau Veritas)	E52
Acceptance certificate (EN 10204-3.1) - Material of pressurized and wetted parts	C12	ABS (American Bureau of Shipping)	E53
Test report - NACE (MR 0103-2012 and MR 0175-2009)	C13	KR (Korean Register of Shipping)	E56
Test report (EN 10204-2.2) - Wetted parts	C14	RINA (Registro Italiano Navale)	E57
Acceptance certificate (EN 10204-3.1) - PMI test of pressurized and wetted parts	C15	CCS (China Classification Society)	E58
Certificates for functional safety		Country-specific approvals	
Functional safety (IEC 61508) - SIL2/3	C20	CRN approval Canada (Canadian Registration Number)	E60

Pressure Measurement

Transmitters for applications with advanced requirements (Advanced)

SITRANS P320/P420

for gauge pressure (differential pressure series)

1

Options	Order code
Special approvals	
Oxygen application (with inert liquid, max. 100 bar (1 450 psi) at 60° C (140 °F))	E80
Dual seal	E81
WRC / WRAS (drinking water); only with pressure cap O-rings made of EPDM	E83
NSF61 (drinking water)	E84
ACS (drinking water)	E85
Mounting bracket	
Steel, galvanized	H01
Stainless steel 1.4301/304	H02
Stainless steel 1.4404/316L	H03
Process flanges; screw plug with vent valve	
Welded in on right	J08
Welded in on left	J09
Glued in on right	J10
Glued in on left	J11
Flange connections with flange EN 1092-1	
Form B1	
• DN 25 PN 40, stainless steel 1.4571/316Ti	J70
• DN 50 PN 40, stainless steel 1.4571/316Ti	J71
• DN 80 PN 40, stainless steel 1.4571/316Ti	J72
• DN 15 PN 40, stainless steel 1.4571/316Ti	J78
Form C	
• DN 25 PN 40, stainless steel 1.4571/316Ti	J73
• DN 50 PN 40, stainless steel 1.4571/316Ti	J74
• DN 80 PN 40, stainless steel 1.4571/316Ti	J75
Flange connection options	
Flange connection and temperature extension	J76
Flange connection with epoxy resin coating	J77
Process flanges; special materials	
Reserved for 7MF7: without process flanges, without screws, without gaskets	K00
Process flange material alloy C4/2.4610	K01
Process flange material Monel 400/2.4360	K02
Process connection material PVDF, on the side ½-14 NPT	K05
Process flanges/process connection material PVDF, flange on the side EN 1092-1 Form B1 DN 25 PN 40, MAWP 4 bar	K06
Process flanges/process connection material PVDF, flange on the side EN 1092-1 Form B1 DN 40 PN 40, MAWP 4 bar	K07
Process flanges; process connection option	
Process flange with process connection G½ welded on	K20
Process connection (oval flange) NAM (ASTAVA)	K21
Process flanges chambered with gaskets	
1x chambered, graphite	K40
1x chambered, PTFE	K41
2x chambered, PTFE	K42
Process flanges, gaskets (instead of standard gaskets FKM (FPM))	
O-ring, process flanges, PTFE	K50
O-ring, process flanges, FEP (with silicone core, approved for food)	K51
O-ring, process flanges, FFKM (FFPM)	K52
O-ring, process flanges, NBR	K53
O-ring, process flanges, EPDM	K54

Options	Order code
Process flange options	
Process flanges for vertical differential pressure lines (half process flange)	K81
Process flanges (+) - side front	K82
Process flange screws, process flange nuts, material Monel 400/2.4360	K83
Valve ¼-18 NPT, material same as process flanges	K84
Valve mounted on the side, measured medium: Gas	K85
Oval flange enclosed, gasket PTFE + mounting screws	K86
Pneumatic blocks	
With mounted pneumatic block (3-way) 7MF9411-5BA, PTFE sealing rings, chrome-plated steel screws and pressure test certified in test report (EN 10204-2.2)	U01
With mounted pneumatic block (3-way) 7MF9411-5BA, PTFE sealing rings, stainless steel screws and pressure test certified in test report (EN 10204-2.2)	U02
With mounted pneumatic block (5-way) 7MF9411-5CA, PTFE sealing rings, chrome-plated steel screws and pressure test certified in test report (EN 10204-2.2)	U03
With mounted pneumatic block (5-way) 7MF9411-5CA, PTFE sealing rings, stainless steel screws and pressure test certified in test report (EN 10204-2.2)	U04

Pressure Measurement

Transmitters for applications with advanced requirements (Advanced)
SITRANS P320/P420

for gauge pressure (differential pressure series)

1

Selection and ordering data

Customer-specific device settings	Order code
Add "-Z" to article no., specify order code and plain text or drop-down list selection.	
Measuring span Start of scale value (max. 5 characters), full scale value (max. 5 characters), unit [mbar, bar, kPa, MPa, psi, ...], example: -0.5 ... 10.5 psi Input field 1 and input field 2: max. 5 characters and numbers only; decimal places as dot (comma is automatically converted to dot). Drop-down list: Pa, MPa, kPa, hPa, bar, mbar, psi, g/cm ² , kg/cm ² , kgf/cm ² , inH ₂ O, inH ₂ O (4°C), ftH ₂ O, mmH ₂ O, mmH ₂ O (4°C), mH ₂ O (4°C), mmHg, inHg, atm, torr	Y01
TAG (on stainless steel plate and device parameters, max. 32 characters) Input field: Free text, max. 32 characters	Y15
Measuring point description (on stainless steel plate and device parameters, max. 32 characters) Input field: Free text, max. 32 characters	Y16
TAG short (device parameters, max. 8 characters) Input field: Free text, max. 8 characters	Y17
Local display [Pressure, Percent], reference [None, Absolute, Relative], example: Pressure gauge Drop-down list: Percent, pressure unit, pressure unit abs., pressure unit gauge	Y21
Local display Scaling with standard units [m³/s, l/s, m, inch, ...], example 1 ... 5 m Input field 1 and input field 2: max. 5 characters and numbers only; decimal places as dot (comma is automatically converted to dot). Drop-down list: m, cm, mm, in, ft, m ³ , l, hl, in ³ , ft ³ , yd ³ , gal, gal (UK), bu, bbl, bbl (US), SCF, Nm ³ , NI.	Y22
Local display Scaling with user-specific units (max. 12 characters), example 1 ... 5 m Input field 1 and input field 2: max. 5 characters and numbers only; decimal places as dot (comma is automatically converted to dot). Input field 3: Free text, max. 8 characters	Y23
Saturation limits instead of 3.8 ... 20.5 mA, example: 3.8 ... 22.0 mA Drop-down list 1: 3.9, 4 Drop-down list 2: 20.8, 22	Y30
Fault current instead of 3.6 mA [22.5 mA, 22.8 mA] Drop-down list: 3.75; 21.75; 22.5; 22.6	Y31
Damping in seconds instead of 2 s (0.0 ... 100.0 s) Input field: max. 4 characters and numbers only; decimal places as dot (comma is automatically converted to dot); min. value = 0; max. value = 100.	Y32
ID number of special version Input field: max. 4 characters and only natural numbers from 0 ... 9999	Y99

Pressure Measurement

Transmitters for applications with advanced requirements (Advanced)

SITRANS P320/P420

for gauge pressure (differential pressure series)

1

Dimensional drawings

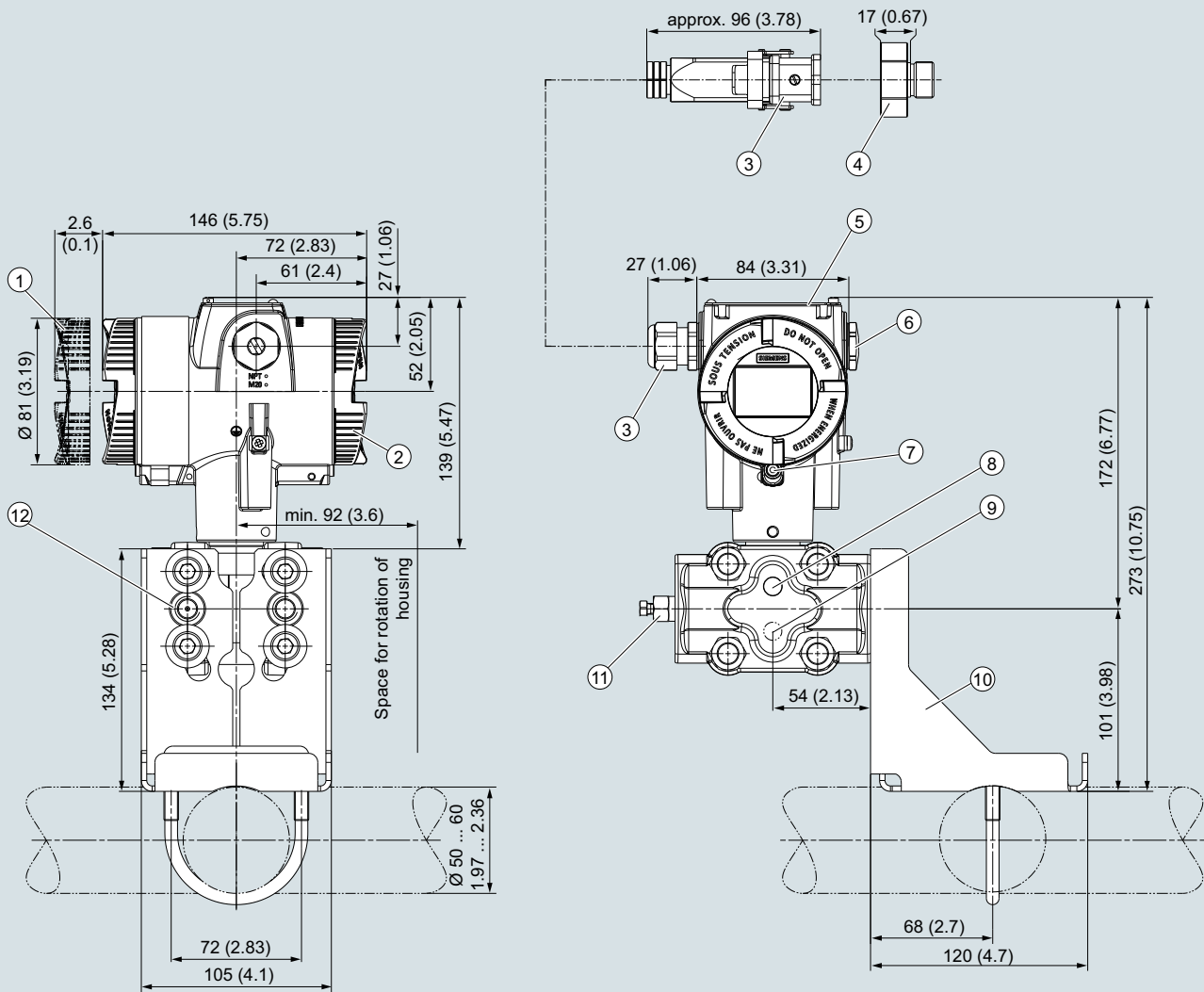

- | | |
|--|---|
| ① Electronic side, display
(longer overall length for cover with window) ¹⁾ | ⑥ Blanking plug |
| ② Terminal side | ⑦ Screw cover - safety bracket
(only for type of protection "Explosion-proof enclosure") |
| ③ Electrical connection:
screw gland M20 x 1,5 ³⁾ or screw gland ½-14 NPT or
Han 7D/Han 8D ^{2) 3)} device plug or M12 device plug ^{2) 3)} | ⑧ Lateral venting for liquid measurement (Standard) |
| ④ Harting adapter | ⑨ Lateral venting for gas measurement (suffix K85) |
| ⑤ Cover over buttons and nameplate with general information | ⑩ Mounting bracket (option) |
| | ⑪ Sealing screw with valve (option) |
| | ⑫ Process connection: ¼-18 NPT (IEC 61518) |

¹⁾ In addition, allow approx. 22 mm (0.87 inch) for the thread length when removing the covers

²⁾ Not with type of protection "Explosion-proof enclosure"

³⁾ Not with type of protection "FM + CSA" [is + XP]"

SITRANS P320/P420 pressure transmitter for relative pressure (differential pressure series), dimensions in mm (inch)

Pressure Measurement

Transmitters for applications with advanced requirements (Advanced)

SITRANS P320/P420

for gauge and absolute pressure, flush-mounted diaphragm

1

Technical specifications

SITRANS P320 / SITRANS P420 for gauge and absolute pressure, with flush-mounted diaphragm

Input of gauge pressure, with flush-mounted diaphragm

Measured variable

Gauge pressure

Span (infinitely adjustable) or measuring range, max. operating pressure and max. test pressure

Span

Max. permissible operating pressure MAWP (PS)

Maximum permissible test pressure

0.01 ... 1 bar
1 ... 100 kPa
0.15 ... 14.5 psi
0.04 ... 4 bar
4 ... 400 kPa
0.58 ... 58 psi
0.16 ... 16 bar
0.016 ... 1.6 MPa
2.3 ... 232 psi
0.6 ... 63 bar
0.063 ... 6.3 MPa
9.1 ... 914 psi

Refer to the information on the nameplate of the pressure transmitter and the data on the mounting flange¹⁾

Measuring limits

- Low measuring limit
 - Measuring cell with silicone oil filling
 - Measuring cell with inert oil
 - Measuring cell with FDA-compliant oil
- Upper measuring limit

100 mbar a/10 kPa a/1.45 psi a
100 mbar a/10 kPa a/1.45 psi a
100 mbar a/10 kPa a/1.45 psi a
100% of max. span

Input of absolute pressure, with flush-mounted diaphragm

Measured variable

Absolute pressure

Span (infinitely adjustable) or measuring range, max. operating pressure and max. test pressure

Span

Max. permissible operating pressure MAWP (PS)

Maximum permissible test pressure

43 ... 1300 mbar a
4.3 ... 130 kPa a
17 ... 525 inH₂O a
166 ... 5000 mbar a
16.6 ... 500 kPa a
2.41 ... 72.5 psi a
1 ... 30 bar a
0.1 ... 3 MPa a
14.5 ... 435 psi a

Refer to the information on the nameplate of the pressure transmitter and the data on the mounting flange¹⁾

Depending on the process connection, the span may differ from these values.

Measuring limits

- Low measuring limit
 - Measuring cell with silicone oil filling
- Upper measuring limit

0 bar a/0 kPa a/0 psi a
100% of max. span

Start of scale

Between the measuring limits (infinitely adjustable)

Output

HART

Output signal

4 ... 20 mA

- Low saturation limit (infinitely adjustable)
- High saturation limit (infinitely adjustable)
- Ripple (without HART communication)

3.55 mA, factory preset to 3.8 mA
22.8 mA, factory-set to 20.5 mA or optionally 22.0 mA
 $I_{pp} \leq 0.5\%$ of max. output current

Adjustable damping

0 ... 100 s, continuously adjustable over remote operation
0 ... 100 s, in increments of 0.1 s, adjustable over display

- Current transmitter
- Failure signal

3.55 ... 22.8 mA
3.55 ... 22.8 mA

Load

Resistor R [Ω]

- Without HART communication

$R = (U_H - 10.5 \text{ V})/22.8 \text{ mA}$,
 U_H : Power supply in V

- With HART communication

$R = 230 \dots 1100 \Omega$ (HART communicator (handheld))
 $R = 230 \dots 500 \Omega$ (SIMATIC PDM)

Characteristic curve

- Linearly increasing or linearly decreasing
- Linear increase or decrease or according to the square root (only for differential pressure and flow)

Physical bus

-

Polarity-independent

-

Pressure Measurement

Transmitters for applications with advanced requirements (Advanced)

SITRANS P320/P420

for gauge and absolute pressure, flush-mounted diaphragm

1

SITRANS P320 / SITRANS P420 for gauge and absolute pressure, with flush-mounted diaphragm

Gauge pressure measuring accuracy, with flush-mounted diaphragm

Reference conditions	<ul style="list-style-type: none"> • According to EN 60770-1 • Rising characteristic curve • Start of scale value 0 bar/kPa/psi • Seal diaphragm stainless steel • Measuring cell with silicone oil filling • Room temperature 25 °C (77 °F)
Conformity error at limit point setting, including hysteresis and repeatability	
Measuring span ratio r (spread, Turn-Down)	r = maximum measuring span/set measuring span or nominal measuring range
• Linear characteristic	
- 1 bar/100 kPa/3.6 psi	$r \leq 5$: $\leq 0.075\%$
4 bar/400 kPa/58 psi	
16 bar/1.6 MPa/232 psi	$5 < r \leq 100$: $\leq (0.005 \cdot r + 0.05)\%$
63 bar/6.3 MPa/914 psi	
Influence of ambient temperature in % per 28 °C (50 °F)	
• 1 bar/100 kPa/3.6 psi	$\leq (0.08 \cdot r + 0.16)\%$
4 bar/400 kPa/58 psi	
16 bar/1.6 MPa/232 psi	
63 bar/6.3 MPa/914 psi	
Long-term stability at ± 30 °C (± 54 °F)	
• 1 bar/100 kPa/3.6 psi	In 5 years $\leq (0.25 \cdot r)\%$
4 bar/400 kPa/58 psi	
16 bar/1.6 MPa/232 psi	
63 bar/6.3 MPa/914 psi	
• 16 bar/1.6 MPa/232 psi	In 5 years $\leq (0.125 \cdot r)\%$
63 bar/6.3 MPa/914 psi	
Step response time T_{63} (without electrical damping)	Approx. 0.1 s
Effect of mounting position (in pressure per change of angle)	0.4 mbar/0.04 kPa/0.006 per 10° incline (zero point correction is possible with position error compensation)
Effect of auxiliary power (in % per voltage change)	0.005% per 1 V

Absolute pressure measuring accuracy with flush diaphragm

Reference conditions	<ul style="list-style-type: none"> • According to EN 60770-1 • Rising characteristic curve • Start of scale value 0 bar/kPa/psi • Seal diaphragm stainless steel • Measuring cell with silicone oil filling • Room temperature 25 °C (77 °F)
Conformity error at limit point setting, including hysteresis and repeatability	
Measuring span ratio r (spread, Turn-Down)	r = maximum measuring span/set measuring span or nominal measuring range
• Linear characteristic	
- All measuring cells	$r \leq 10$: $\leq 0.2\%$
	$10 < r \leq 30$: $\leq 0.4\%$
Influence of ambient temperature in % per 28 °C (50 °F)	
• All measuring cells	$\leq (0.16 \cdot r + 0.24)\%$
Long-term stability at ± 30 °C (± 54 °F)	
• All measuring cells	In 5 years $\leq (0.25 \cdot r)\%$
Step response time T_{63} (without electrical damping)	Approx. 0.2 s
Effect of mounting position (in pressure per change of angle)	0.4 mbar/0.04 kPa/0.006 per 10° incline (zero point correction is possible with position error compensation)
Effect of auxiliary power (in % per voltage change)	0.005% per 1 V

Pressure Measurement

Transmitters for applications with advanced requirements (Advanced)

SITRANS P320/P420

for gauge and absolute pressure, flush-mounted diaphragm

SITRANS P320 / SITRANS P420 for gauge and absolute pressure, with flush-mounted diaphragm

Rated conditions

Temperature of medium²⁾

- Measuring cell with silicone oil filling
-40 ... +150 °C (-40 ... +302 °F)
-40 ... +200 °C (-40 ... +392 °F) with cooling extension
- Measuring cell with inert oil
-20 ... +100 °C (-4 ... +212 °F)
- Measuring cell with FDA-compliant oil
-10 ... +150 °C (14 ... +302 °F)
-10 ... +200 °C (14 ... +392 °F) with cooling extension

Ambient conditions

- Ambient temperature/enclosure
 - Measuring cell with silicone oil filling
-40 ... +85 °C (-40 ... +185 °F)
 - Measuring cell with inert oil (different pressure classes)

1 bar/100 kPa/3.6 psi	-40 ... +100 °C (-40 ... +212 °F)
4 bar/400 kPa/58 psi	
16 bar/1.6 MPa/232 psi	
63 bar/6.3 MPa/914 ps	
160 bar/16 MPa/2321 psi	-20 ... +100 °C (-4 ... +212 °F)
400 bar/40 MPa/5802 psi	
700 bar/70 MPa/10152 ps	
 - Measuring cell with FDA-compliant oil
-10 ... +85 °C (14 ... +185 °F)
 - Display
-20 ... +80 °C (-4 ... +176 °F)
- Storage temperature
-50 ... +85 °C (-58 ... +185 °F) (with FDA-compliant oil: -20 ... +85 °C (-4 ... +185 °F))
- Climatic class in accordance with IEC 60721-3-4
4K4H
- Degree of protection
 - According to IEC 60529
IP66, IP68
 - According to NEMA 250
Type 4X
- Electromagnetic compatibility
 - Emitted interference and interference immunity
According to IEC 61326 and NAMUR NE 21

Design

Weight (pressure transmitter without mounting flange)

Material

- Wetted parts materials
 - Process connection
Stainless steel, mat. no. 1.4404/316L
 - Seal diaphragm
Stainless steel, material no. 1.4404/316L or Alloy C276, material no. 2.4819
- Non-wetted parts materials
 - Electronics housing
 - Low-copper die-cast aluminum GD-AISI 12 or stainless steel precision casting, mat. no. 1.4409/ CF-3M
 - Standard: Powder coating with polyurethane
Option: 2 coats: Coat 1: epoxy-based; coat 2: Polyurethane
 - Stainless steel type plate (1.4404/316L)
 - Mounting bracket
Steel, electrogalvanized steel, or stainless steel
- Process connection
 - Flanges according to EN and ASME
 - F&B and pharmaceutical flanges
 - BioConnect/BioControl
 - PMC style
- Electrical connection
Cable entry via the following screwed glands:
 - M20 x 1.5
 - ½-14 NPT
 - Han 7D/Han 8D device plug³⁾
 - M12 device plug

Displays and controls

- Keys
4 keys for operation directly on the device
- Display
 - With or without integrated display (optional)
 - Cover with inspection window (optional)

Auxiliary power U_H

- Terminal voltage on pressure transmitter
10.5 ... 45 V DC
10.5 ... 30 V DC in intrinsically safe mode
- Ripple
 $U_{ss} \leq 0.2 \text{ V}$ (47 ... 125 Hz)
- Noise
 $U_{eff} \leq 1.2 \text{ mV}$ (0.5 ... 10 kHz)
- Auxiliary power
–
- Separate supply voltage
–

Pressure Measurement

Transmitters for applications with advanced requirements (Advanced)

SITRANS P320/P420

for gauge and absolute pressure, flush-mounted diaphragm

1

SITRANS P320 / SITRANS P420 for gauge and absolute pressure, with flush-mounted diaphragm

Certificates and approvals

Classification according to pressure equipment directive (PED 2014/68/EU)

For gases of fluid group 1 and liquids of fluid group 1; complies with requirements of article 4, paragraph 3 (sound engineering practice)

Drinking water

- WRAS (England)
- ACS (France)
- DVGW (Germany)
- NSF (USA)

Available soon

Available soon

Available soon

Available soon

CRN (Canada)

Available soon

Explosion protection acc. to NEPSI (China)

Available soon

Explosion protection acc. to INMETRO (Brazil)

Available soon

BAM (Germany), oxygen expenditures

Available soon

Explosion protection

- Intrinsic safety "i"

- Marking

II 1/2 G Ex ia/ib IIC T4/T6 Ga/Gb

- Permissible ambient temperature

-40 ... +80 °C (-40 ... +176 °F) temperature class T4

-40 ... +70 °C (-40 ... +158 °F) temperature class T6

- Permissible temperature of measuring medium

-40 ... +100 °C (-40 ... +212 °F) temperature class T4

-40 ... +70 °C (-40 ... +158 °F) temperature class T6

- Connection

To certified intrinsically safe circuits with peak values:

$U_i = 30 \text{ V}$, $I_i = 101 \text{ mA}$, $P_i = 760 \text{ mW}$

$U_i = 29 \text{ V}$, $I_i = 110 \text{ mA}$, $P_i = 800 \text{ mW}$

$L_i = 0.24 \text{ } \mu\text{H}/C_i = 3.29 \text{ nF}$

- Effective internal inductance/capacitance

- Flameproof enclosure "d"

- Marking

Ex II 1/2 G Ex ia/db IIC T4/T6 Ga/Gb

- Permissible ambient temperature

-40 ... +80 °C (-40 ... +176 °F) temperature class T4

-40 ... +70 °C (-40 ... +158 °F) temperature class T6

- Permissible temperature of measuring medium

-40 ... +100 °C (-40 ... +212 °F) temperature class T4

-40 ... +70 °C (-40 ... +158 °F) temperature class T6

- Connection

To a circuit with the operating values:

$U_n = 10.5 \text{ to } 45 \text{ V}$, $4 \text{ ... } 20 \text{ mA}$

- Dust explosion protection for Zone 20, 21, 22

- Marking

Ex II 1D Ex tb IIIC T120 °C Da

Ex II 2D Ex tb IIIC T120 °C Db

Ex II 3D Ex tc IIIC T120 °C Dc

- Permissible ambient temperature

-40 ... +80 °C (-40 ... +176 °F)

- Permissible temperature of measuring medium

-40 ... +100 °C (-40 ... +212 °F)

- Max. surface temperature

120 °C (248 °F)

- Connection

To a circuit with the operating values:

$U_n = 10.5 \text{ to } 45 \text{ V}$, $4 \text{ ... } 20 \text{ mA}$

- Dust explosion protection for Zone 20, 21, 22

- Marking

Ex II 1D Ex ia IIIC T120 °C Da

Ex II 2D Ex ib IIIC T120 °C Db

Ex II 3D Ex ic IIIC T120 °C Dc

- Permissible ambient temperature

-40 ... +80 °C (-40 ... +176 °F)

- Permissible temperature of measuring medium

-40 ... +100 °C (-40 ... +212 °F)

- Connection

To certified intrinsically safe circuits with the peak values:

$U_i = 30 \text{ V}$, $I_i = 101 \text{ mA}$, $P_i = 760 \text{ mW}$

$U_i = 29 \text{ V}$, $I_i = 110 \text{ mA}$, $P_i = 800 \text{ mW}$

$L_i = 0.24 \text{ } \mu\text{H}/C_i = 3.29 \text{ nF}$

- Effective internal inductance/capacitance

- Type of protection for Zone 2

- Marking

Ex II 3G Ex ec IIC T4/T6 Gc

Ex II 3G Ex ic IIC T4/T6 Gc

- Permissible ambient temperature "ec"

-40 ... +80 °C (-40 ... +176 °F) temperature class T4

-40 ... +40 °C (-40 ... +104 °F) temperature class T6

- Permissible ambient temperature "ic"

-40 ... +80 °C (-40 ... +176 °F) temperature class T4

-40 ... +80 °C (-40 ... +176 °F) temperature class T6

- Permissible temperature of measuring medium

-40 ... +100 °C (-40 ... +212 °F) temperature class T4

-40 ... +70 °C (-40 ... +158 °F) temperature class T6

- "ec" connection

To a circuit with the operating values:

$U_n = 10.5 \text{ to } 30 \text{ V}$, $4 \text{ ... } 20 \text{ mA}$

- "ic" connection

To certified intrinsically safe circuits with the peak values:

$U_i = 30 \text{ V}$, $I_i = 101 \text{ mA}$, $P_i = 760 \text{ mW}$

$U_i = 29 \text{ V}$, $I_i = 110 \text{ mA}$, $P_i = 800 \text{ mW}$

Effective internal inductance/capacitance:

$L_i = 0.24 \text{ } \mu\text{H}/C_i = 3.29 \text{ nF}$

Pressure Measurement

Transmitters for applications with advanced requirements (Advanced)

SITRANS P320/P420

for gauge and absolute pressure, flush-mounted diaphragm

SITRANS P320 / SITRANS P420 for gauge and absolute pressure, with flush-mounted diaphragm

• Explosion protection acc. to FM - Marking (XP/DIP) or IS; NI; S	Available soon CL I, DIV 1, GP ABCD T4 ... T6; CL II, DIV 1, GP EFG; CL III; Ex ia IIC T4 ... T6: CL I, DIV 2, GP ABCD T4 ... T6; CL II, DIV 2, GP FG; CL III
• Explosion protection according to CSA - Marking (XP/DIP) or (IS)	Available soon CL I, DIV 1, GP ABCD T4 ... T6; CL II, DIV 1, GP EFG; CL III; Ex ia IIC T4 ... T6: CL I, DIV 2, GP ABCD T4 ... T6; CL II, DIV 2, GP FG; CL III

- 1) The MAWP value of the pressure transmitter can be lower than the PN value of the mounting flange and vice versa. To determine the maximum permissible operating pressure and the maximum permissible test pressure, use the lowest value as reference.
- 2) Observe the temperature limits in the process connection standards (e.g. DIN 32676 and DIN 11851) for the maximum process temperature for flush-mounted process connections.
- 3) Han 8D is identical to Han 8U.

HART communication

HART	230 ... 1100 Ω
Protocol	HART 7
Software for computer	SIMATIC PDM

Pressure Measurement

Transmitters for applications with advanced requirements (Advanced)

SITRANS P320/P420

for gauge and absolute pressure, flush-mounted diaphragm

1

Selection and ordering data

	Article No.
Pressure transmitter for gauge and absolute pressure, with flush-mounted diaphragm	
SITRANS P320 for gauge pressure	↗ 7MF030 - - - - -
SITRANS P420 for gauge pressure	↗ 7MF040 - - - - -
SITRANS P320 for absolute pressure	↗ 7MF032 - - - - -
SITRANS P420 for absolute pressure	↗ 7MF042 - - - - -
↗ Click on the Article no. for the online configuration in the PIA Life Cycle Portal.	
Communication	
HART, 4 ... 20 mA	0
Measuring cell filling	
Silicone oil	1
Inert liquid	3
Neobee oil	4
Maximum measuring span	
1000 mbar (14.5 psi)	0 J
4000 mbar (58 psi)	0 N
16 bar (232 psi)	0 Q
63 bar (914 psi)	0 T
1 300 mbar a (18.9 psi a)	2 L
5000 mbar a (72.5 psi a)	2 P
30 bar a (435 psi a)	2 R
Process connection	
Flush-mounted diaphragm	K
Wetted parts materials: Process connection, seal diaphragm	
Stainless steel 316L/1.4404, stainless steel 316L/1.4404	0
Stainless steel 316L/1.4404, alloy C276/2.4819	1
Alloy C22/2.4602, alloy C276/2.4819	2
Non-wetted parts materials	
Die-cast aluminum	1
Stainless steel precision casting CF3M/1.4409 similar to 316L	2
Enclosure	
Dual chamber device	5
Type of protection	
Without Ex	A
Intrinsic safety	B
Flameproof enclosure	C
Flameproof enclosure, intrinsic safety	D
Dust protection by enclosure Zone 21/22 (DIP), increased safety Zone 2	L
Dust protection by enclosure Zone 20/21/22 (DIP), increased safety Zone 2	M
Combination of options B, C and L (zone model)	S
Combination of options B, C and M (zone model, Class Division)	T
Electrical connections/cable entries	
Thread for cable gland	F
• 2 x M20 x 1.5	M
• 2 x ½-14 NPT	
Local operation/display	
Without display (cover closed)	0
With display (cover closed)	1
With display (cover with glass pane)	2

Pressure Measurement

Transmitters for applications with advanced requirements (Advanced)

SITRANS P320/P420

for gauge and absolute pressure, flush-mounted diaphragm

1

Selection and ordering data

Options	Order code	Options	Order code
Add "-Z" to article no. and specify order code.			
Cable glands included		Device options	
Plastic	A00	PDF file with device settings	D10
Metal	A01	Double layer coating (epoxy resin and polyurethane) 120 µm of enclosure and cover	D20
Stainless steel	A02	FVMQ enclosure sealing	D21
Stainless steel 316L/1.4404	A03	IP66/IP68 degree of protection (not for M12 and Han device plugs)	D30
CMP, for XP devices	A10	TAG label empty	D40
CAPRI ADE 4F, CuZn, cable inner diameter 7 ... 12 mm, cable outer diameter 10 ... 16 mm	A11	Without labeling of the measuring range on the TAG label	D41
CAPRI ADE 4F, stainless steel, cable inner diameter 7 ... 12 mm, cable outer diameter 10 ... 16 mm	A12	Stainless steel Ex plate 1.4404/316L	D42
Han device plug mounted left		Increase of pressure stage from PN 420 to PN 500	D50
Han 7D device plug (plastic, straight)	A30	Overvoltage protection up to 6 kV (external)	D71
Han 7D device plug (plastic, angled)	A31	Adhesive labels on transport packaging (supplied by customer)	D90
Han 7D device plug (metal, straight)	A32		
Han 7D device plug (metal, angled)	A33	General approval without Ex approval	
Han 8D device plug (plastic, straight)	A34	Worldwide (CE, RCM) except EAC, FM, CSA, KCC	E00
Han 8D device plug (plastic, angled)	A35	Worldwide (CE, RCM, EAC, FM, CSA, KCC)	E01
Han 8D device plug (metal, straight)	A36	CSA	E06
Han 8D device plug (metal, angled)	A37	EAC	E07
Cable socket included		FM	E08
Plastic, for Han 7D/8D device plugs	A40	KCC	E09
Metal, for Han 7D/8D device plugs	A41	UL	E10
M12 device plug mounted left		Explosion protection approvals	
Stainless steel, without cable socket	A62	ATEX (Europe)	E20
Stainless steel, with cable socket	A63	CSA (USA and Canada)	E21
Cable entry/connector mounting		FM (USA and Canada)	E22
2x sealing plugs M20 x 1.5, IP66/68 installed on both sides	A90	IECEX (Worldwide)	E23
2x sealing plugs ½-14 NPT, IP66/68 installed on both sides	A91	EACEx (GOST-R, -K, -B)	E24
Cable gland/connector mounted left	A97	INMETRO (Brazil)	E25
Cable gland/connector mounted on right	A99	KCs (Korea)	E26
Nameplate labeling		NEPSI (China)	E27
German (bar)	B11	PESO (India)	E28
French (bar)	B12	TIIS Hazardous (Japan)	E29
Spanish (bar)	B13	UKR Sepro (Ukraine)	E30
Italian (bar)	B14	ATEX (Europe) and IECEx (Worldwide)	E47
Chinese (bar)	B15	CSA (Canada) and FM (USA)	E48
Russian (bar)	B16	ATEX (Europe) and IECEx (Worldwide) + CSA (Canada) and FM (USA)	E49
English (psi)	B20	Marine approvals	
Chinese (Pa)	B35	DNV-GL (Det Norske Veritas/Germanischer Lloyd)	E50
Certificates		LR (Lloyds Register)	E51
Quality test certificate, 5-point factory calibration (IEC 60770-2)	C11	BV (Bureau Veritas)	E52
Acceptance certificate (EN 10204-3.1) - Material of pressurized and wetted parts	C12	ABS (American Bureau of Shipping)	E53
Test report - NACE (MR 0103-2012 and MR 0175-2009)	C13	KR (Korean Register of Shipping)	E56
Test report (EN 10204-2.2) - Wetted parts	C14	RINA (Registro Italiano Navale)	E57
Acceptance certificate (EN 10204-3.1) - PMI test of pressurized and wetted parts	C15	CCS (China Classification Society)	E58
Certificates for functional safety		Country-specific approvals	
Functional safety (IEC 61508) - SIL2/3	C20	CRN approval Canada (Canadian Registration Number)	E60
		Special approvals	
		Oxygen application (with inert liquid, max. 100 bar (1 450 psi) at 60° C (140 °F))	E80
		Dual seal	E81
		WRC / WRAS (drinking water); only with pressure cap O-rings made of EPDM	E83
		NSF61 (drinking water)	E84

Pressure Measurement

Transmitters for applications with advanced requirements (Advanced)

SITRANS P320/P420

for gauge and absolute pressure, flush-mounted diaphragm

1

Options	Order code	Options	Order code
ACS (drinking water)	E85	Sanitary connections manufacturer-specific	
3A (hygiene)	E86	Varivent type N for pipes DN 40 ... DN 125 PN 40	P06
EHEDG (hygiene)	E87	NEUMO BioConnect flange	
Process flanges, gaskets (instead of standard gaskets FKM (FPM))		• DN 50 PN 16	P14
Seal (EN 837-1) material Fe (soft iron)	K60	• DN 65 PN 16	P15
Seal (EN 837-1) material 1.4571	K61	• DN 80 PN 16	P16
Seal (EN 837-1) material Cu	K62	• DN100 PN 16	P17
Process connection		• 2" PN 16	P23
Process connection male thread G½, bore hole 11 mm	K80	• 2 ½" PN 16	P24
		• 3" PN 16	P25
		• 4" PN 16	P26
Flanges according to DIN EN 1092-1 Form B1 and ASME standard B16.5		NEUMO BioConnect clamp	
EN 1092-1 Form B1		• DN 50 PN 16	P34
• DN 50 PN 16	M03	• DN 65 PN 10	P35
• DN 80 PN 16	M05	• DN 80 PN 10	P36
• DN 25 PN 40	M10	• DN 100 PN 10	P37
• DN 40 PN 40	M12	• 2 ½" PN 16	P43
• DN 50 PN 40	M13	• 3" PN 10	P44
• DN 80 PN 40	M15	• 4" PN 10	P45
• DN 40 PN 100	M22	NEUMO BioControl flange	
ASME B16.5		• DN 50 PN 16	P51
• 1" Class 150 RF	M30	• DN 65 PN 16	P52
• 1 ½" Class 150 RF	M31	• DN 80 PN 16	P53
• 2" Class 150 RF	M32		
• 3" Class 150 RF	M33	Sanitary connections special design	
• 4" Class 150 RF	M34	Tank connection	
• 1" Class 300 RF	M35	• TG 52/50 PN 40 with seal	Q00
• 1 ½" Class 300 RF	M36	• TG 52/150 PN 40 with seal	Q01
• 2" Class 300 RF	M37	DRD flange D = 65 mm DN 50 PN 40	Q15
• 3" Class 300 RF	M38	SMS socket	
• 4" Class 300 RF	M39	• with union nut 2" PN 25	Q22
		• with union nut 2 ½" PN 25	Q23
Sanitary connections in accordance with the standard		• with union nut 3" PN 25	Q24
Sanitary flange DIN 11851		• with thread 2" PN 25	Q28
• with slotted union nut DN 50 PN 25	N03	• with thread 2 ½" PN 25	Q29
• with slotted union nut DN 80 PN 25	N05	• with thread 3" PN 25	Q30
Tri-Clamp		IDF socket	
• DIN 32676 DN 50 PN 16	N14	• with union nut ISO 2853 2" PN 25	Q42
• DIN 32676 DN 65 PN 10	N15	• with union nut ISO 2853 2 ½" PN 25	Q43
• ISO 2852 2" PN 40	N22	• with union nut ISO 2853 3" PN 25	Q44
• ISO 2852 3" PN 40	N23	• with thread ISO 2853 2" PN 25	Q48
Aseptic threaded socket		• with thread ISO 2853 2 ½" PN 25	Q49
• DIN 11864-1 Form A DN 50 PN 25	N33	• with thread ISO 2853 3" PN 25	Q50
• DIN 11864-1 Form A DN 65 PN 25	N34		
• DIN 11864-1 Form A DN 80 PN 25	N35	Weldable sockets for tank connection	
• DIN 11864-1 Form A DN100 PN 25	N36	Weldable piece for TG52/50	Q90
Aseptic flange with notch		Weldable piece for TG52/150	Q91
• DIN 11864-2 Form A DN 50 PN 16	N43	Connections for the paper industry	
• DIN 11864-2 Form A DN 65 PN 16	N44	Process connection PMC Style Standard	R00
• DIN 11864-2 Form A DN 80 PN 16	N45	Process connection PMC Style Minibolt	R01
• DIN 11864-2 Form A DN100 PN 16	N46	Weldable sockets for PMC Style Standard	R02
Aseptic clamp with groove		Weldable sockets for PMC Style Minibolt	R03
• DIN 11864-3 Form A DN 50 PN 25	N53	Threaded connection	
• DIN 11864-3 Form A DN 65 PN 25	N54	Male thread G¾-A DIN 3852	R11
• DIN 11864-3 Form A DN 80 PN 16	N55	Male thread G1-A DIN 3852	R12
• DIN 11864-3 Form A DN100 PN 16	N56	Male thread G2-A DIN 3852	R14
		Special options front-flush	
		Temperature decoupler (media temperature up to 200 °C)	R85
		Mating connector including seal	R90

Pressure Measurement

Transmitters for applications with advanced requirements (Advanced)
SITRANS P320/P420

for gauge and absolute pressure, flush-mounted diaphragm

1

Selection and ordering data

Customer-specific device settings	Order code
Add "-Z" to article no., specify order code and plain text or drop-down list selection.	
Measuring span Start of scale value (max. 5 characters), full scale value (max. 5 characters), unit [mbar, bar, kPa, MPa, psi, ...], example: -0.5 ... 10.5 psi Input field 1 and input field 2: max. 5 characters and numbers only; decimal places as dot (comma is automatically converted to dot). Drop-down list: Pa, MPa, kPa, hPa, bar, mbar, psi, g/cm ² , kg/cm ² , kgf/cm ² , inH ₂ O, inH ₂ O (4°C), ftH ₂ O, mmH ₂ O, mmH ₂ O (4°C), mH ₂ O (4°C), mmHg, inHg, atm, torr	Y01
TAG (on stainless steel plate and device parameters, max. 32 characters) Input field: Free text, max. 32 characters	Y15
Measuring point description (on stainless steel plate and device parameters, max. 32 characters) Input field: Free text, max. 32 characters	Y16
TAG short (device parameters, max. 8 characters) Input field: Free text, max. 8 characters	Y17
Local display [Pressure, Percent], reference [None, Absolute, Relative], example: Pressure gauge Drop-down list: Percent, pressure unit, pressure unit abs., pressure unit gauge	Y21
Local display Scaling with standard units [m³/s, l/s, m, inch, ...], example 1 ... 5 m Input field 1 and input field 2: max. 5 characters and numbers only; decimal places as dot (comma is automatically converted to dot). Drop-down list: m, cm, mm, in, ft, m ³ , l, hl, in ³ , ft ³ , yd ³ , gal, gal (UK), bu, bbl, bbl (US), SCF, Nm ³ , NI.	Y22
Local display Scaling with user-specific units (max. 12 characters), example 1 ... 5 m Input field 1 and input field 2: max. 5 characters and numbers only; decimal places as dot (comma is automatically converted to dot). Input field 3: Free text, max. 8 characters	Y23
Saturation limits instead of 3.8 ... 20.5 mA, example: 3.8 ... 22.0 mA Drop-down list 1: 3.9, 4 Drop-down list 2: 20.8, 22	Y30
Fault current instead of 3.6 mA [22.5 mA, 22.8 mA] Drop-down list: 3.75; 21.75; 22.5; 22.6	Y31
Damping in seconds instead of 2 s (0.0 ... 100.0 s) Input field: max. 4 characters and numbers only; decimal places as dot (comma is automatically converted to dot); min. value = 0; max. value = 100.	Y32
ID number of special version Input field: max. 4 characters and only natural numbers from 0 ... 9999	Y99

Dimensional drawings

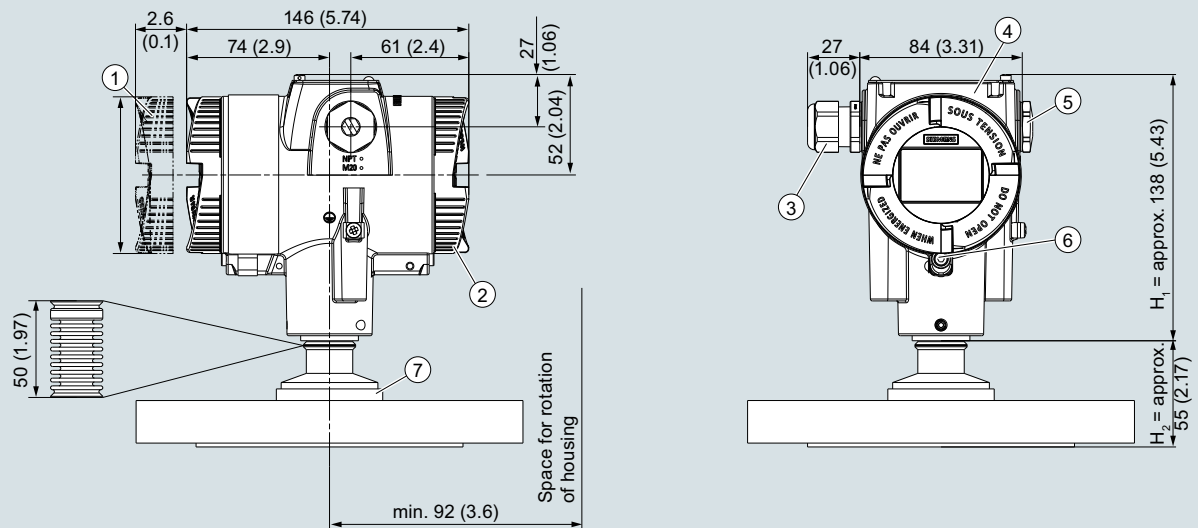

- | | |
|---|--|
| <ul style="list-style-type: none"> ① Electronic side, display
(longer overall length for cover with window)¹⁾ ② Terminal side ③ Electrical connection:
screw gland M20 x 1,5³⁾ or screw gland ½-14 NPT or
Han 7D/Han 8D^{2) 3)} device plug or M12 device plug^{2) 3)} | <ul style="list-style-type: none"> ④ Cover over buttons and nameplate with general information ⑤ Blanking plug ⑥ Screw cover - safety bracket
(only for type of protection "Explosion-proof enclosure") ⑦ Process connection |
|---|--|

¹⁾ In addition, allow approx. 22 mm (0.87 inch) for the thread length when removing the covers

²⁾ Not with type of protection "Explosion-proof enclosure"

³⁾ Not with type of protection "FM + CSA" [is + XP]"

SITRANS P320/P420 pressure transmitter, with flush-mounted diaphragm, dimensions in mm (inch)

This figure consists of a SITRANS P320/P420 with an example flange.

In this figure, the height is divided into H_1 and H_2 .

H_1 = Height of the SITRANS P320/P420 up to a defined cross-section

H_2 = Height of the flange up to this defined cross-section

Only the height H_2 is indicated in the dimensions of the flanges.

Pressure Measurement

Transmitters for applications with advanced requirements (Advanced)
SITRANS P320/P420

for gauge and absolute pressure, flush-mounted diaphragm

Flanges according to EN and ASME

Flange according to EN

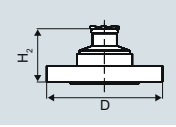
EN 1092-1					
	Order code	DN	PN	ØD	H ₂
	M03	50	16	165 mm (6.5")	Approx. 52 mm (2")
	M05	80	16	200 mm (7.9")	
	M10	25	40	115 mm (4.5")	
	M12	40	40	150 mm (5.9")	
	M13	50	40	165 mm (6.5")	
	M15	80	40	200 mm (7.9")	
	M22	40	100	170 mm (6.7")	

Flanges according to ASME

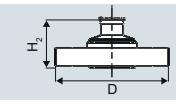
ASME B16.5					
	Order code	DN	Class	ØD	H ₂
	M30	1"	150	110 mm (4.3")	Approx. 52 mm (2")
	M31	1½"	150	130 mm (5.1")	
	M32	2"	150	150 mm (5.9")	
	M33	3"	150	190 mm (7.5")	
	M34	4"	150	230 mm (9.1")	
	M35	1"	300	125 mm (4.9")	
	M36	1½"	300	155 mm (6.1")	
	M37	2"	300	165 mm (6.5")	
	M38	3"	300	210 mm (8.1")	
	M39	4"	300	255 mm (10.0")	

NuG and pharmaceutical connections

Connections to DIN

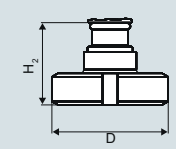
DIN 11851 (milk pipe union with slotted union nut)					
	Order code	DN	PN	ØD	H ₂
	N03	50	25	92 mm (3.6")	Approx. 52 mm (2")
	N05	80	25	127 mm (5.0")	

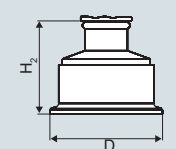
TriClamp according to DIN 32676					
	Order code	DN	PN	ØD	H ₂
	N14	50	16	64 mm (2.5")	Approx. 52 mm (2")
	N15	65	10	91 mm (3.6")	
	N22	2"	16	64 mm (2.5")	Approx. 52 mm (2")
	N23	3"	10	91 mm (3.6")	

Other connections

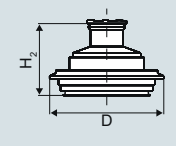
Varivent connection					
	Order code	DN	PN	ØD	H ₂
	P06	40 ... 125	40	84 mm (3.3")	Approx. 52 mm (2")

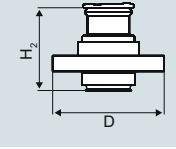
Bio-control connection					
	Order code	DN	PN	ØD	H ₂
	P51	50	16	90 mm (3.5")	Approx. 52 mm (2")
	P52	65	16	120 mm (4.7")	
	P53	80	16	150 mm (5.9")	

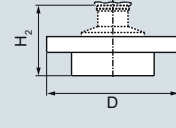
Sanitary process connection according to DRD					
	Order code	DN	PN	ØD	H ₂
	Q15	65	40	105 mm (4.1")	Approx. 52 mm (2")

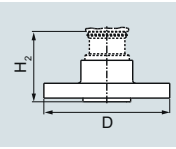
Sanitary process connection according to NEUMO BioConnect flange connection					
	Order code	DN	PN	ØD	H ₂
	P14	50	16	110 mm (4.3")	Approx. 52 mm (2")
	P15	65	16	140 mm (5.5")	
	P16	80	16	150 mm (5.9")	
	P17	100	16	175 mm (6.9")	
	P23	2"	16	100 mm (3.9")	
	P24	2½"	16	110 mm (4.3")	
	P25	3"	16	140 mm (5.5")	
	P26	4"	16	175 mm (6.9")	

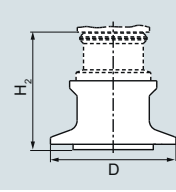
Sanitary process connection according to NEUMO BioConnect clamp connection					
	Order code	DN	PN	ØD	H ₂
	P34	50	16	77.4 mm (3.0")	Approx. 52 mm (2")
	P35	65	10	90.9 mm (3.6")	
	P36	80	10	106 mm (4.2")	
	P37	100	10	119 mm (4.7")	
	P43	2½"	16	77.4 mm (3.0")	
	P44	3"	10	90.9 mm (3.6")	
	P45	4"	10	119 mm (4.7")	

Pressure Measurement

Transmitters for applications with advanced requirements (Advanced)
SITRANS P320/P420

for gauge and absolute pressure, flush-mounted diaphragm

1

Threaded connection G $\frac{3}{4}$ " , G1" and G2" acc. to DIN 3852

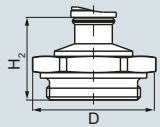
	Order code	DN	PN	$\varnothing D$	H ₂
	R11	$\frac{3}{4}$ "	63	37 mm (1.5")	Approx. 45 mm (1.8")
	R12	1"	63	48 mm (1.9")	Approx. 47 mm (1.9")
	R14	2"	63	78 mm (3.1")	Approx. 52 mm (2")

Tank connection TG 52/50 and TG52/150

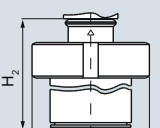
	Order code	DN	PN	$\varnothing D$	H ₂
	Q00	25	40	63 mm (2.5")	Approx. 63 mm (2.5")
	Q01	25	40	63 mm (2.5")	Approx. 170 mm (6.7")

SMS socket with union nut

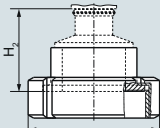
	Order code	DN	PN	$\varnothing D$	H ₂
	Q22	2"	25	84 mm (3.3")	Approx. 52 mm (2.1")
	Q23	2 $\frac{1}{2}$ "	25	100 mm (3.9")	
	Q24	3"	25	114 mm (4.5")	

SMS threaded socket

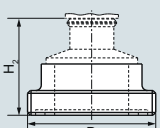
	Order code	DN	PN	$\varnothing D$	H ₂
	Q28	2"	25	70 x 1/6 mm	Approx. 52 mm (2.1")
	Q29	2 $\frac{1}{2}$ "	25	85 x 1/6 mm	
	Q30	3"	25	98 x 1/6 mm	

IDF socket with union nut

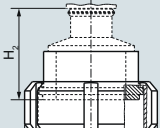
	Order code	DN	PN	$\varnothing D$	H ₂
	Q28	2"	25	77 mm (3")	Approx. 52 mm (2.1")
	Q29	2 $\frac{1}{2}$ "	25	91 mm (3.6")	
	Q30	3"	25	106 mm (4.2")	

IDF threaded socket

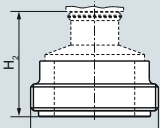
	Order code	DN	PN	$\varnothing D$	H ₂
	Q48	2"	25	64 mm (2.5")	Approx. 52 mm (2.1")
	Q49	2 $\frac{1}{2}$ "	25	77.5 mm (3.1")	
	Q50	3"	25	91 mm (3.6")	

Aseptic threaded socket according to DIN 11864-1 Form A

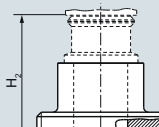
	Order code	DN	PN	$\varnothing D$	H ₂
	N33	50	25	78 x 1/6"	Approx. 52 mm (2.1")
	N34	65	25	95 x 1/6"	
	N35	80	25	110 x 1/4"	
	N36	100	25	130 x 1/4"	

Aseptic flange with notch to DIN 11864-2 Form A

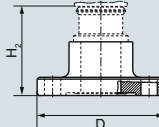
	Order code	DN	PN	$\varnothing D$	H ₂
	N43	50	16	94 (3.7")	Approx. 52 mm (2.1")
	N44	65	16	113 (4.4")	
	N45	80	16	133 (5.2")	
	N46	100	16	159 (6.3")	

Aseptic clamp with groove according to DIN 11864-3 Form A

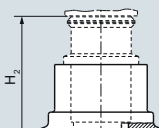
	Order code	DN	PN	$\varnothing D$	H ₂
	N53	50	25	77.5 (3.1")	Approx. 52 mm (2.1")
	N54	65	25	91 (3.6")	
	N55	80	16	106 (4.2")	
	N56	100	16	130 (5.1")	

Process connection PMC Style Standard

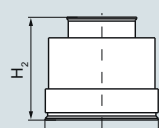
	Order code	DN	PN	$\varnothing D$	H ₂
	R00	-	-	40.9 mm (1.6")	Approx. 36.8 mm (1.4")

Process connection PMC Style Minibolt

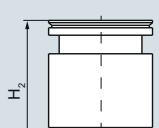
	Order code	DN	PN	$\varnothing D$	H ₂
	R01	-	-	26.3 mm (1.0")	Approx. 33.1 mm (1.3")

Pressure Measurement

Transmitters for applications with advanced requirements (Advanced)

SITRANS P320/P420

for absolute pressure (pressure series)

1

Technical specifications

SITRANS P320 / SITRANS P420 for absolute pressure (pressure series)

Input

Measured variable	Absolute pressure	Max. permissible operating pressure MAWP (PS)	Maximum permissible test pressure
Span (infinitely adjustable) or measuring range, max. permissible operating pressure (in accordance with Pressure Equipment Directive 2014/68/EU) and max. test pressure (pursuant to DIN 16086)	Span		
	8.3 ... 250 mbar a	4 bar a	6 bar a
	0.83 ... 25 kPa a	0.4 MPa a	0.6 MPa a
	3.3 ... 100.5 inH ₂ O a	58 psi a	87 psi a
	43 ... 1300 mbar a	6.6 bar a	10 bar a
	4.3 ... 130 kPa a	0.66 MPa a	1 MPa a
	17.3 ... 522 inH ₂ O a	95 psi a	145 psi a
	166 ... 5000 mbar a	20 bar a	30 bar a
	16.6 ... 500 kPa a	2 MPa a	3 MPa a
	2.41 ... 72.5 psi a	290 psi a	435 psi a
	1 ... 30 bar a	65 bar a	100 bar a
	0.1 ... 3 MPa a	6.5 MPa a	10 MPa a
	14.5 ... 435 psi a	942 psi a	1450 psi a
	5.3 ... 160 bar a	240 bar	380 bar a
	0.53 ... 16 MPa a	24 MPa	38 MPa a
	77 ... 2321 psi a	3480 psi	5511 psi a
	13.3 ... 400 bar a	400 bar a	600 bar a
	1.3 ... 40 MPa a	40 MPa a	60 MPa a
	192 ... 5802 psi a	5802 psi a	8702 psi a
	23.3 ... 700 bar a	800 bar a	800 bar a
	2.3 ... 70 MPa a	80 MPa a	80 MPa a
	337 ... 10153 psi a	11603 psi a	11603 psi a
Measuring limits			
• Low measuring limit	0 mbar a/kPa a/psi a		
- Measuring cell with silicone oil filling	For process temperature -20 °C < ϑ ≤ +60 °C (-4 °F < ϑ ≤ +140 °F)		30 mbar a/3 kPa a/0.44 psi a
- Measuring cell with inert oil	For process temperature 60 °C < ϑ ≤ +100 °C (max. 85 °C for measuring cell 30 bar) (140 °F < ϑ ≤ +212 °F (max. 185 °F for measuring cell 435 psi))		30 mbar a + 20 mbar a · (ϑ - 60 °C)/°C 3 kPa a + 2 kPa a · (ϑ - 60 °C)/°C 0.44 psi a + 0.29 psi a · (ϑ - 140 °F)/°F
• Upper measuring limit	100% of the max. measuring span (for oxygen measurement max. 100 bar/10 MPa/ 1450 psi and 60 °C (140 °F) ambient temperature/process temperature)		
• Start of scale	Between the measuring limits (infinitely adjustable)		

Output

Output signal	HART
• Low saturation limit (infinitely adjustable)	4 ... 20 mA
• High saturation limit (infinitely adjustable)	3.55 mA, factory preset to 3.8 mA
• Ripple (without HART communication)	22.8 mA, factory-set to 20.5 mA or optionally 22.0 mA
Adjustable damping	$I_{pp} \leq 0.5\%$ of max. output current
• Current transmitter	0 ... 100 s, continuously adjustable over remote operation
• Failure signal	0 ... 100 s, in increments of 0.1 s, adjustable over display
Load	3.55 ... 22.8 mA
• Without HART communication	3.55 ... 22.8 mA
• With HART communication	Resistor R [Ω]
Characteristic curve	$R = (U_H - 10.5 \text{ V})/22.8 \text{ mA}$, U_H : Power supply in V
Physical bus	$R = 230 \dots 1100 \Omega$ (HART communicator (handheld))
Polarity-independent	$R = 230 \dots 500 \Omega$ (SIMATIC PDM)
	• Linearly increasing or linearly decreasing
	• Linear increase or decrease or according to the square root (only for differential pressure and flow)

Pressure Measurement

Transmitters for applications with advanced requirements (Advanced)

SITRANS P320/P420

for absolute pressure (pressure series)

1

SITRANS P320 / SITRANS P420 for absolute pressure (pressure series)**Measuring accuracy**

Reference conditions	<ul style="list-style-type: none"> • According to EN 60770-1 • Rising characteristic curve • Start of scale value 0 bar/kPa/psi • Seal diaphragm stainless steel • Measuring cell with silicone oil filling • Room temperature 25 °C (77 °F)
Conformity error at limit point setting, including hysteresis and repeatability	
Measuring span ratio r (spread, Turn-Down)	r = maximum measuring span/set measuring span or nominal measuring range
<ul style="list-style-type: none"> • Linear characteristic (all measuring cells) 	
- r ≤ 10	≤ 0.1%
- 10 < r ≤ 30	≤ 0.2%
Influence of ambient temperature (in % per 28 °C (50 °F))	
<ul style="list-style-type: none"> • 250 mbar a/25 kPa a/3.6 psi a • 1300 mbar a/130 kPa a/18.8 psi a • 5 bar a/500 kPa a/72.5 psi a • 30 bar a/3000 kPa a/435 psi a • 100 bar a/10 MPa a/1450 psi a • 160 bar a/16 MPa a/2321 psi a • 400 bar a/40 MPa a/5802 psi a • 700 bar a/70 MPa a/10153 psi a 	<ul style="list-style-type: none"> ≤ (0.15 · r + 0.1)% ≤ (0.08 · r + 0.16)%
Long-term stability at ±30 °C (±54 °F)	In 5 years ≤ (0.25 · r)%
Step response time T ₆₃ (without electrical damping)	Approx. 0.2 s
Effect of mounting position (in pressure per change of angle)	≤ 0.05 mbar/0.005 kPa/0.000725 psi per 10° incline (zero point correction is possible with position error compensation)
Effect of auxiliary power (in % per voltage change)	0.005% per 1 V

Rated conditions

Temperature of medium	
<ul style="list-style-type: none"> • Measuring cell with silicone oil filling • Measuring cell with inert oil 	-40 ... +100 °C (-40 ... +212 °F)
<ul style="list-style-type: none"> - 1 bar/100 kPa/3.6 psi - 4 bar/400 kPa/58 psi - 16 bar/1.6 MPa/232 psi - 63 bar/6.3 MPa/914 psi 	-40 ... +85 °C (-40 ... +185 °F)
<ul style="list-style-type: none"> - 160 bar/16 MPa/2321 psi - 400 bar/40 MPa/5802 psi - 700 bar/70 MPa/10153 psi 	-20 ... +100 °C (-4 ... +212 °F)
<ul style="list-style-type: none"> • Measuring cell with FDA-compliant oil 	-10 ... +100 °C (14 ... +212 °F)
Ambient conditions	
<ul style="list-style-type: none"> • Ambient temperature/enclosure 	Observe the temperature class in areas subject to explosion hazard.
<ul style="list-style-type: none"> - Measuring cell with silicone oil filling - Measuring cell with inert oil for gauge pressure measuring cells: 1 bar/100 kPa/3.6 psi 4 bar/400 kPa/58 psi 16 bar/1.6 MPa/232 psi 63 bar/6.3 MPa/914 psi - Measuring cell with inert oil - Measuring cell with FDA-compliant oil - Display 	<ul style="list-style-type: none"> -40 ... +85 °C (-40 ... +185 °F) -40 ... +85 °C (-40 ... +185 °F) -20 ... +85 °C (-4 ... +185 °F) -10 ... +85 °C (14 ... +185 °F) -20 ... +80 °C (-4 ... +176 °F) -50 ... +85 °C (-58 ... +185 °F) (with FDA-compliant oil: -20 ... + 85 °C (-4 ... +185 °F))
<ul style="list-style-type: none"> • Storage temperature • Climatic class in accordance with IEC 60721-3-4 • Degree of protection 	<ul style="list-style-type: none"> 4K4H
<ul style="list-style-type: none"> - According to IEC 60529 - According to NEMA 250 	<ul style="list-style-type: none"> IP66, IP68 Type 4X
<ul style="list-style-type: none"> • Electromagnetic compatibility - Emitted interference and interference immunity 	<ul style="list-style-type: none"> According to IEC 61326 and NAMUR NE 21

Pressure Measurement

Transmitters for applications with advanced requirements (Advanced)

SITRANS P320/P420

for absolute pressure (pressure series)

SITRANS P320 / SITRANS P420 for absolute pressure (pressure series)

Design

Weight	Approx. 2.3 kg (5.07 lb) with aluminum enclosure Approx. 4.2 kg (9.25 lb) for stainless steel enclosure
Material	
• Wetted parts materials	
- Process connection	Stainless steel, material no. 1.4404/316L or Alloy C22, material no. 2.4602
- Oval flange	Stainless steel, mat. no. 1.4404/316L
- Seal diaphragm	Stainless steel, material no. 1.4404/316L or Alloy C276, material no. 2.4819
• Non-wetted parts materials	
- Electronics housing	<ul style="list-style-type: none"> • Low-copper die-cast aluminum GD-AISI 12 or stainless steel precision casting, mat. no. 1.4409/ CF-3M • Standard: Powder coating with polyurethane • Option: 2 coats: Coat 1: epoxy-based; coat 2: Polyurethane • Stainless steel type plate (1.4404/316L)
- Mounting bracket	Electrogalvanized steel or stainless steel
Process connection	<ul style="list-style-type: none"> • Connection shank G1/2A according to DIN EN 837-1 • Female thread 1/2-14 NPT • Male thread M20 x 1.5 and 1/2-14 NPT • Oval flange (PN 160 (MWP 2320 psi g)) with fastening screw thread: • Oval flange (PN 420 (MWP 2320 psi g)) with fastening screw thread: <ul style="list-style-type: none"> - 7/16-20 UNF according to EN 61518 - M10 according to DIN 19213 • Oval flange (PN 420 (MWP 2320 psi g)) with fastening screw thread: <ul style="list-style-type: none"> - 7/16-20 UNF according to EN 61518 - M12 according to DIN 19213 • Male thread M20 x 1.5 and 1/2-14 NPT
Electrical connection	<p>Cable entry via the following screwed glands:</p> <ul style="list-style-type: none"> • M20 x 1.5 • 1/2-14 NPT • Han 7D/Han 8D device plug¹⁾ • M12 device plug

Displays and controls

Keys	4 keys for operation directly on the device
Display	<ul style="list-style-type: none"> • With or without integrated display (optional) • Cover with inspection window (optional)

Auxiliary power U_H

Terminal voltage on pressure transmitter	10.5 ... 45 V DC 10.5 ... 30 V DC in intrinsically safe mode
Ripple	$U_{SS} \leq 0.2 \text{ V}$ (47 ... 125 Hz)
Noise	$U_{eff} \leq 1.2 \text{ mV}$ (0.5 ... 10 kHz)
Auxiliary power	-
Separate supply voltage	-

Certificates and approvals

Classification according to pressure equipment directive (PED 2014/68/EU)	For gases of fluid group 1 and liquids of fluid group 1; complies with requirements of article 4, paragraph 3 (sound engineering practice)
Drinking water	
• WRAS (England)	Available soon
• ACS (France)	Available soon
• DVGW (Germany)	Available soon
• NSF (USA)	Available soon
CRN (Canada)	Available soon
Explosion protection acc. to NEPSI (China)	Available soon
Explosion protection acc. to INMETRO (Brazil)	Available soon
BAM (Germany), oxygen expenditures	Available soon

Pressure Measurement

Transmitters for applications with advanced requirements (Advanced)

SITRANS P320/P420

for absolute pressure (pressure series)

1

SITRANS P320 / SITRANS P420 for absolute pressure (pressure series)

Explosion protection

- Intrinsic safety "i"

- Marking II 1/2 G Ex ia/ib IIC T4/T6 Ga/Gb
- Permissible ambient temperature -40 ... +80 °C (-40 ... +176 °F) temperature class T4
-40 ... +70 °C (-40 ... +158 °F) temperature class T6
- Permissible temperature of measuring medium -40 ... +100 °C (-40 ... +212 °F) temperature class T4
-40 ... +70 °C (-40 ... +158 °F) temperature class T6
- Connection To certified intrinsically safe circuits with peak values:
 $U_i = 30 \text{ V}$, $I_i = 101 \text{ mA}$, $P_i = 760 \text{ mW}$
 $U_i = 29 \text{ V}$, $I_i = 110 \text{ mA}$, $P_i = 800 \text{ mW}$
 $L_i = 0.24 \text{ } \mu\text{H/C}_i = 3.29 \text{ nF}$
- Effective internal inductance/capacitance

- Flameproof enclosure "d"

- Marking Ex II 1/2 G Ex ia/db IIC T4/T6 Ga/Gb
- Permissible ambient temperature -40 ... +80 °C (-40 ... +176 °F) temperature class T4
-40 ... +70 °C (-40 ... +158 °F) temperature class T6
- Permissible temperature of measuring medium -40 ... +100 °C (-40 ... +212 °F) temperature class T4
-40 ... +70 °C (-40 ... +158 °F) temperature class T6
- Connection To a circuit with the operating values:
 $U_n = 10.5 \text{ to } 45 \text{ V}$, $4 \text{ ... } 20 \text{ mA}$

- Dust explosion protection for Zone 20, 21, 22

- Marking Ex II 1D Ex tb IIIC T120 °C Da
Ex II 2D Ex tb IIIC T120 °C Db
Ex II 3D Ex tc IIIC T120 °C Dc
- Permissible ambient temperature -40 ... +80 °C (-40 ... +176 °F)
- Permissible temperature of measuring medium -40 ... +100 °C (-40 ... +212 °F)
- Max. surface temperature 120 °C (248 °F)
- Connection To a circuit with the operating values:
 $U_n = 10.5 \text{ to } 45 \text{ V}$, $4 \text{ ... } 20 \text{ mA}$

- Dust explosion protection for Zone 20, 21, 22

- Marking Ex II 1D Ex ia IIIC T120 °C Da
Ex II 2D Ex ib IIIC T120 °C Db
Ex II 3D Ex ic IIIC T120 °C Dc
- Permissible ambient temperature -40 ... +80 °C (-40 ... +176 °F)
- Permissible temperature of measuring medium -40 ... +100 °C (-40 ... +212 °F)
- Connection To certified intrinsically safe circuits with the peak values:
 $U_i = 30 \text{ V}$, $I_i = 101 \text{ mA}$, $P_i = 760 \text{ mW}$
 $U_i = 29 \text{ V}$, $I_i = 110 \text{ mA}$, $P_i = 800 \text{ mW}$
 $L_i = 0.24 \text{ } \mu\text{H/C}_i = 3.29 \text{ nF}$
- Effective internal inductance/capacitance

- Type of protection for Zone 2

- Marking Ex II 3G Ex ec IIC T4/T6 Gc
Ex II 3G Ex ic IIC T4/T6 Gc
- Permissible ambient temperature "ec" -40 ... +80 °C (-40 ... +176 °F) temperature class T4
-40 ... +40 °C (-40 ... +104 °F) temperature class T6
- Permissible ambient temperature "ic" -40 ... +80 °C (-40 ... +176 °F) temperature class T4
-40 ... +80 °C (-40 ... +176 °F) temperature class T6
- Permissible temperature of measuring medium -40 ... +100 °C (-40 ... +212 °F) temperature class T4
-40 ... +70 °C (-40 ... +158 °F) temperature class T6
- "ec" connection To a circuit with the operating values:
 $U_n = 10.5 \text{ to } 30 \text{ V}$, $4 \text{ ... } 20 \text{ mA}$
- "ic" connection To certified intrinsically safe circuits with the peak values:
 $U_i = 30 \text{ V}$, $I_i = 101 \text{ mA}$, $P_i = 760 \text{ mW}$
 $U_i = 29 \text{ V}$, $I_i = 110 \text{ mA}$, $P_i = 800 \text{ mW}$
Effective internal inductance/capacitance:
 $L_i = 0.24 \text{ } \mu\text{H/C}_i = 3.29 \text{ nF}$

- Explosion protection acc. to FM

- Marking (XP/DIP) or IS; NI; S

- Explosion protection according to CSA

- Marking (XP/DIP) or (IS)

Available soon
CL I, DIV 1, GP ABCD T4 ... T6; CL II, DIV 1, GP EFG; CL III; Ex ia IIC T4 ... T6: CL I, DIV 2, GP ABCD T4 ... T6; CL II, DIV 2, GP FG; CL III

Available soon

CL I, DIV 1, GP ABCD T4 ... T6; CL II, DIV 1, GP EFG; CL III; Ex ia IIC T4 ... T6: CL I, DIV 2, GP ABCD T4 ... T6; CL II, DIV 2, GP FG; CL III

1) Han 8D is identical to Han 8U.

HART communication

HART	230 ... 1100 Ω
Protocol	HART 7
Software for computer	SIMATIC PDM

Pressure Measurement

Transmitters for applications with advanced requirements (Advanced)

SITRANS P320/P420

for absolute pressure (pressure series)

1

Selection and ordering data

	Article No.
Pressure transmitters for absolute pressure (pressure series)	
SITRANS P320	7MF032 - - - - -
SITRANS P420	7MF042 - - - - -
Click on the Article no. for the online configuration in the PIA Life Cycle Portal.	
Communication	
HART, 4 ... 20 mA	0
Measuring cell filling	
Silicone oil	1
Inert liquid	3
Neobee oil	4
Maximum measuring span	
250 mbar a (100.5 inH ₂ O a)	F
1 300 mbar a (522 inH ₂ O a)	L
5000 mbar a (72.5 psi a)	P
30 bar a (435 psi a)	R
160 bar a (2 321 psi a)	V
400 bar a (5 802 psi a)	W
700 bar a (10153 psi a)	X
Process connection	
Male thread M20 x 1.5	B
Male thread G $\frac{1}{2}$ (DIN EN 837-1)	D
Female thread $\frac{1}{2}$ -14 NPT	E
Male thread $\frac{1}{2}$ -14 NPT	F
Oval flange, mounting thread: $\frac{7}{16}$ -20 UNF (IEC 61518)	G
Oval flange, mounting thread: M10 (DIN 19213)	H
Oval flange, mounting thread: M12 (DIN 19213)	J
Version for diaphragm seal pressure	U
Wetted parts materials: Process connection, seal diaphragm	
Stainless steel 316L/1.4404, stainless steel 316L/1.4404	0
Stainless steel 316L/1.4404, alloy C276/2.4819	1
Alloy C22/2.4602, alloy C276/2.4819	2
Non-wetted parts materials	
Die-cast aluminum	1
Stainless steel precision casting CF3M/1.4409 similar to 316L	2
Enclosure	
Dual chamber device	5
Type of protection	
Without Ex	A
Intrinsic safety	B
Flameproof enclosure	C
Flameproof enclosure, intrinsic safety	D
Dust protection by enclosure Zone 21/22 (DIP), increased safety Zone 2	L
Dust protection by enclosure Zone 20/21/22 (DIP), increased safety Zone 2	M
Combination of options B, C and L (zone model)	S
Combination of options B, C and M (zone model, Class Division)	T
Electrical connections/cable entries	
Thread for cable gland	
• 2 x M20 x 1.5	F
• 2 x $\frac{1}{2}$ -14 NPT	M
Local operation/display	
Without display (cover closed)	0
With display (cover closed)	1
With display (cover with glass pane)	2

Pressure Measurement

Transmitters for applications with advanced requirements (Advanced)

SITRANS P320/P420

for absolute pressure (pressure series)

1

Selection and ordering data

<i>Options</i>	Order code	<i>Options</i>	Order code
Add "-Z" to article no. and specify order code.		Device options	
Cable glands included		PDF file with device settings	D10
Plastic	A00	Double layer coating (epoxy resin and polyurethane) 120 µm of enclosure and cover	D20
Metal	A01	FVMQ enclosure sealing	D21
Stainless steel	A02	IP66/IP68 degree of protection (not for M12 and Han device plugs)	D30
Stainless steel 316L/1.4404	A03	TAG label empty	D40
CMP, for XP devices	A10	Without labeling of the measuring range on the TAG label	D41
CAPRI ADE 4F, CuZn, cable inner diameter 7 ... 12 mm, cable outer diameter 10 ... 16 mm	A11	Stainless steel Ex plate 1.4404/316L	D42
CAPRI ADE 4F, stainless steel, cable inner diameter 7 ... 12 mm, cable outer diameter 10 ... 16 mm	A12	Increase of pressure stage from PN 420 to PN 500	D50
Han device plug mounted left		Overvoltage protection up to 6 kV (external)	D71
Han 7D device plug (plastic, straight)	A30	Adhesive labels on transport packaging (supplied by customer)	D90
Han 7D device plug (plastic, angled)	A31		
Han 7D device plug (metal, straight)	A32	General approval without Ex approval	
Han 7D device plug (metal, angled)	A33	Worldwide (CE, RCM) except EAC, FM, CSA, KCC	E00
Han 8D device plug (plastic, straight)	A34	Worldwide (CE, RCM, EAC, FM, CSA, KCC)	E01
Han 8D device plug (plastic, angled)	A35	CSA	E06
Han 8D device plug (metal, straight)	A36	EAC	E07
Han 8D device plug (metal, angled)	A37	FM	E08
Cable socket included		KCC	E09
Plastic, for Han 7D/8D device plugs	A40	UL	E10
Metal, for Han 7D/8D device plugs	A41	Explosion protection approvals	
M12 device plug mounted left		ATEX (Europe)	E20
Stainless steel, without cable socket	A62	CSA (USA and Canada)	E21
Stainless steel, with cable socket	A63	FM (USA and Canada)	E22
Cable entry/connector mounting		IECEX (Worldwide)	E23
2x sealing plugs M20 x 1.5, IP66/68 installed on both sides	A90	EACEx (GOST-R, -K, -B)	E24
2x sealing plugs ½-14 NPT, IP66/68 installed on both sides	A91	INMETRO (Brazil)	E25
Cable gland/connector mounted left	A97	KCs (Korea)	E26
Cable gland/connector mounted on right	A99	NEPSI (China)	E27
Nameplate labeling		PESO (India)	E28
German (bar)	B11	TIIS Hazardous (Japan)	E29
French (bar)	B12	UKR Sepro (Ukraine)	E30
Spanish (bar)	B13	ATEX (Europe) and IECEX (Worldwide)	E47
Italian (bar)	B14	CSA (Canada) and FM (USA)	E48
Chinese (bar)	B15	ATEX (Europe) and IECEX (Worldwide) + CSA (Canada) and FM (USA)	E49
Russian (bar)	B16	Marine approvals	
English (psi)	B20	DNV-GL (Det Norske Veritas/Germanischer Lloyd)	E50
Chinese (Pa)	B35	LR (Lloyds Register)	E51
Certificates		BV (Bureau Veritas)	E52
Quality test certificate, 5-point factory calibration (IEC 60770-2)	C11	ABS (American Bureau of Shipping)	E53
Acceptance certificate (EN 10204-3.1) - Material of pressurized and wetted parts	C12	KR (Korean Register of Shipping)	E56
Test report - NACE (MR 0103-2012 and MR 0175-2009)	C13	RINA (Registro Italiano Navale)	E57
Test report (EN 10204-2.2) - Wetted parts	C14	CCS (China Classification Society)	E58
Acceptance certificate (EN 10204-3.1) - PMI test of pressurized and wetted parts	C15	Country-specific approvals	
Certificates for functional safety		CRN approval Canada (Canadian Registration Number)	E60
Functional safety (IEC 61508) - SIL2/3	C20		

Pressure Measurement

Transmitters for applications with advanced requirements (Advanced)

SITRANS P320/P420

for absolute pressure (pressure series)

1

Options	Order code
Special approvals	
Oxygen application (with inert liquid, max. 100 bar (1 450 psi) at 60° C (140 °F))	E80
Dual seal	E81
WRC / WRAS (drinking water); only with pressure cap O-rings made of EPDM	E83
NSF61 (drinking water)	E84
ACS (drinking water)	E85
Mounting bracket	
Steel, galvanized	H01
Stainless steel 1.4301/304	H02
Stainless steel 1.4404/316L	H03
Flange connections with flange EN 1092-1	
With flange adapter G½ Form B1	
• DN 25 PN 40, stainless steel 1.4571/316Ti	J80
• DN 50 PN 40, stainless steel 1.4571/316Ti	J81
• DN 80 PN 40, stainless steel 1.4571/316Ti	J82
With siphon G½ Form B1	
• DN 25 PN 40, stainless steel 1.4571/316Ti	J83
• DN 50 PN 40, stainless steel 1.4571/316Ti	J84
• DN 80 PN 40, stainless steel 1.4571/316Ti	J85
• DN 25 PN 100, stainless steel 1.4571/316Ti	J86
Process flanges, gaskets (instead of standard gaskets FKM (FPM))	
Seal (EN 837-1) material Fe (soft iron)	K60
Seal (EN 837-1) material 1.4571	K61
Seal (EN 837-1) material Cu	K62
Process connection	
Process connection male thread G½, bore hole 11 mm	K80
Shut-off valves, pneumatic blocks	
With mounted pneumatic block 7MF9011-4EA, process connection at transmitter G½ shank, PTFE sealing ring and pressure test certified in test report (EN 10204-2.2)	T02
With mounted pneumatic block 7MF9011-4FA, process connection at transmitter female thread ½-14 NPT, sealing tape. With PTFE sealing ring and pressure test certified in test report (EN 10204-2.2)	T03
With mounted pneumatic block 7MF9411-5AA, process connection at transmitter oval flange with PTFE gasket, steel mounting screws, pressure test certified in test report (EN 10204-2.2)	T05
With mounted pneumatic block 7MF9411-5AA, process connection at transmitter oval flange with PTFE gasket, stainless steel mounting screws, pressure test certified in test report (EN 10204-2.2)	T06

Selection and ordering data

Customer-specific device settings	Order code
Add "-Z" to article no., specify order code and plain text or drop-down list selection.	
Measuring span Start of scale value (max. 5 characters), full scale value (max. 5 characters), unit [mbar, bar, kPa, MPa, psi, ...], example: -0.5 ... 10.5 psi	Y01
Input field 1 and input field 2: max. 5 characters and numbers only; decimal places as dot (comma is automatically converted to dot). Drop-down list: Pa, MPa, kPa, hPa, bar, mbar, psi, g/cm ² , kg/cm ² , kgf/cm ² , inH ₂ O, inH ₂ O (4°C), ftH ₂ O, mmH ₂ O, mmH ₂ O (4°C), mH ₂ O (4°C), mmHg, inHg, atm, torr	
TAG (on stainless steel plate and device parameters, max. 32 characters)	Y15
Input field: Free text, max. 32 characters	
Measuring point description (on stainless steel plate and device parameters, max. 32 characters)	Y16
Input field: Free text, max. 32 characters	
TAG short (device parameters, max. 8 characters)	Y17
Input field: Free text, max. 8 characters	
Local display [Pressure, Percent], reference [None, Absolute, Relative], example: Pressure gauge	Y21
Drop-down list: Percent, pressure unit, pressure unit abs., pressure unit gauge	
Local display Scaling with standard units [m³/s, l/s, m, inch, ...], example 1 ... 5 m	Y22
Input field 1 and input field 2: max. 5 characters and numbers only; decimal places as dot (comma is automatically converted to dot). Drop-down list: m, cm, mm, in, ft, m ³ , l, hl, in ³ , ft ³ , yd ³ , gal, gal (UK), bu, bbl, bbl (US), SCF, Nm ³ , NI.	
Local display Scaling with user-specific units (max. 12 characters), example 1 ... 5 m	Y23
Input field 1 and input field 2: max. 5 characters and numbers only; decimal places as dot (comma is automatically converted to dot). Input field 3: Free text, max. 8 characters	
Saturation limits instead of 3.8 ... 20.5 mA, example: 3.8 ... 22.0 mA	Y30
Drop-down list 1: 3.9, 4 Drop-down list 2: 20.8, 22	
Fault current instead of 3.6 mA [22.5 mA, 22.8 mA]	Y31
Drop-down list: 3.75; 21.75; 22.5; 22.6	
Damping in seconds instead of 2 s (0.0 ... 100.0 s)	Y32
Input field: max. 4 characters and numbers only; decimal places as dot (comma is automatically converted to dot); min. value = 0; max. value = 100.	
ID number of special version	Y99
Input field: max. 4 characters and only natural numbers from 0 ... 9999	

Pressure Measurement

Transmitters for applications with advanced requirements (Advanced)

SITRANS P320/P420

for absolute pressure (pressure series)

1

Dimensional drawings

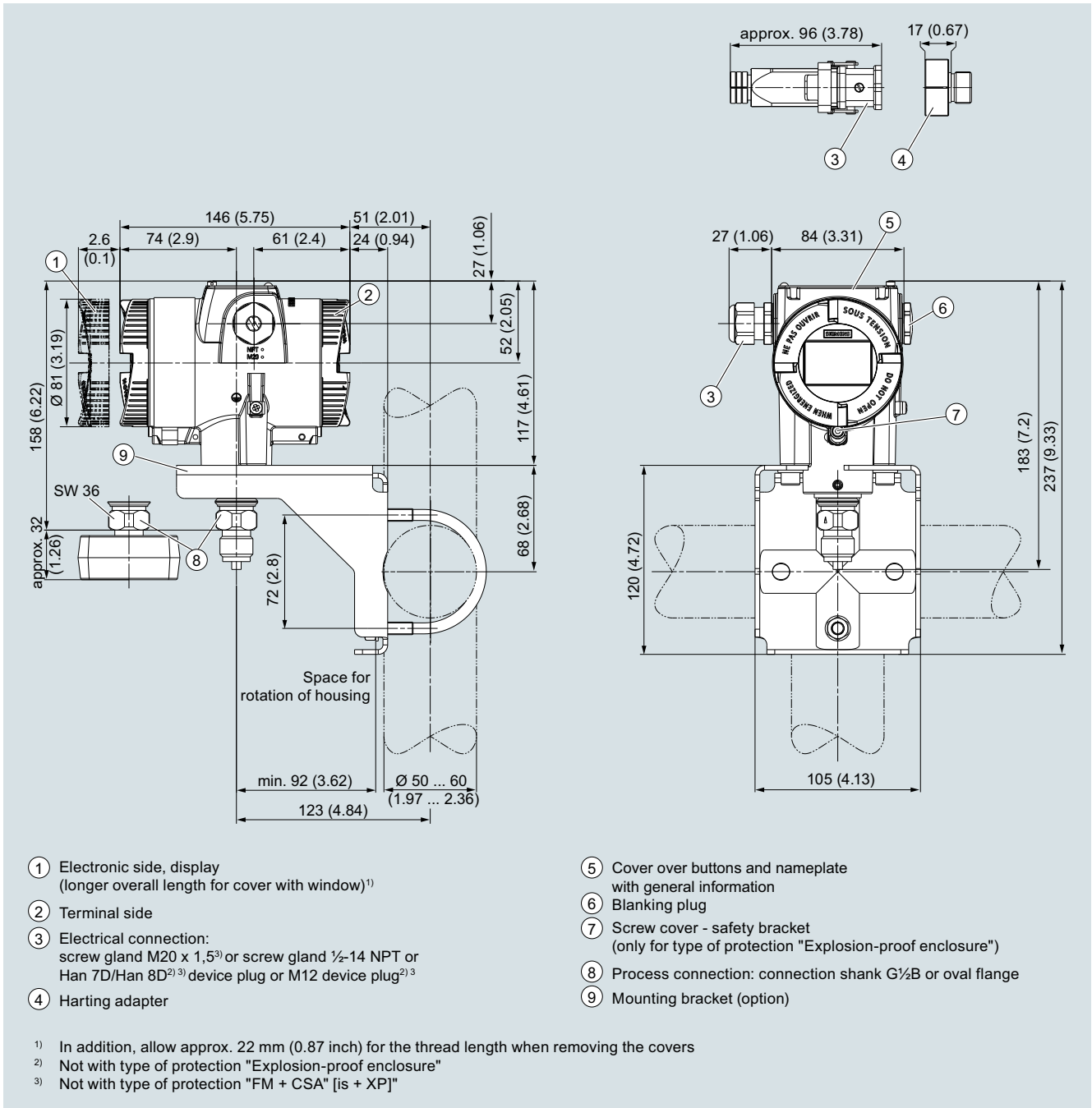

SITRANS P320/P420 pressure transmitter for absolute pressure (pressure series), dimensions in mm (inch)

Pressure Measurement

Transmitters for applications with advanced requirements (Advanced)

SITRANS P320/P420

for absolute pressure (differential pressure series)

1

Technical specifications

SITRANS P320 / SITRANS P420 for absolute pressure (differential pressure series)

Input

Measured variable	Absolute pressure		
Span (infinitely adjustable) and maximum operating pressure (pursuant to Pressure Equipment Directive 2014/68/EU)	Span	Max. permissible operating pressure MAWP (PS)	Maximum permissible test pressure
	8.3 ... 250 mbar a	32 bar a	48 bar a
	0.83 ... 25 kPa a	3.2 MPa a	4.8 MPa a
	3.3 ... 100.5 inH ₂ O a	464 psi a	696 psi a
	43 ... 1300 mbar a	32 bar a	48 bar a
	4.3 ... 130 kPa a	3.2 MPa a	4.8 MPa a
	17.3 ... 522 inH ₂ O a	464 psi a	696 psi a
	166 ... 5000 mbar a	32 bar a	240 bar a
	16.6 ... 500 kPa a	3.2 MPa a	24 MPa a
	2.41 ... 72.5 psi a	464 psi a	3480 psi a
	1 ... 30 bar a	160 bar a	240 bar a
	0.1 ... 3 MPa a	16 MPa a	24 MPa a
	14.5 ... 435 psi a	2320 psi a	3480 psi a
	5 ... 100 bar a	160 bar a	240 bar a
	0.5 ... 10 MPa a	16 MPa a	24 MPa a
	76.9 ... 1450 psi a	2320 psi a	3480 psi a
Measuring limits			
• Low measuring limit	0 mbar a/kPa a/psi a		
- Measuring cell with silicone oil filling	For process temperature $-20\text{ °C} < \vartheta \leq +60\text{ °C}$ ($-4\text{ °F} < \vartheta \leq +140\text{ °F}$)		30 mbar a/3 kPa a/0.44 psi a
- Measuring cell with inert liquid	For process temperature $60\text{ °C} < \vartheta \leq +100\text{ °C}$ (max. 85 °C for measuring cell 30 bar) ($140\text{ °F} < \vartheta \leq +212\text{ °F}$ (max. 185 °F for measuring cell 435 psi))		$30\text{ mbar a} + 20\text{ mbar a} \cdot (\vartheta - 60\text{ °C})/\text{°C}$ $3\text{ kPa a} + 2\text{ kPa a} \cdot (\vartheta - 60\text{ °C})/\text{°C}$ $0.44\text{ psi a} + 0.29\text{ psi a} \cdot (\vartheta - 140\text{ °F})/\text{°F}$
• Upper measuring limit	100% of the max. measuring span (for oxygen measurement max. 100 bar/10 MPa/ 1450 psi and 60 °C (140 °F) ambient temperature/process temperature)		
• Start of scale	Between the measuring limits (infinitely adjustable)		

Output

Output signal	HART
• Low saturation limit (infinitely adjustable)	4 ... 20 mA
• High saturation limit (infinitely adjustable)	3.55 mA, factory preset to 3.8 mA
• Ripple (without HART communication)	22.8 mA, factory-set to 20.5 mA or optionally 22.0 mA
Adjustable damping	$I_{pp} \leq 0.5\%$ of max. output current
• Current transmitter	0 ... 100 s, continuously adjustable over remote operation
• Failure signal	0 ... 100 s, in increments of 0.1 s, adjustable over display
Load	3.55 ... 22.8 mA
• Without HART communication	3.55 ... 22.8 mA
• With HART communication	Resistor R [Ω] $R = (U_H - 10.5\text{ V})/22.8\text{ mA}$, U_H : Power supply in V $R = 230 \dots 1100\ \Omega$ (HART communicator (handheld)) $R = 230 \dots 500\ \Omega$ (SIMATIC PDM)
Characteristic curve	<ul style="list-style-type: none"> • Linearly increasing or linearly decreasing • Linear increase or decrease or according to the square root (only for differential pressure and flow)
Physical bus	-
Polarity-independent	-

Measuring accuracy

Reference conditions	<ul style="list-style-type: none"> • According to EN 60770-1 • Rising characteristic curve • Start of scale value 0 bar/kPa/psi • Seal diaphragm stainless steel • Measuring cell with silicone oil filling • Room temperature 25 °C (77 °F)
----------------------	--

Pressure Measurement

Transmitters for applications with advanced requirements (Advanced)

SITRANS P320/P420

for absolute pressure (differential pressure series)

1

SITRANS P320 / SITRANS P420 for absolute pressure (differential pressure series)

Conformity error / limit point setting, including hysteresis and repeatability

Measuring span ratio r (spread, Turn-Down)
 • Linear characteristic (all measuring cells)

- $r \leq 10$
- $10 < r \leq 30$

r = maximum measuring span/set measuring span or nominal measuring range

- $\leq 0.1\%$
- $\leq 0.2\%$

Influence of ambient temperature
 (in % per 28 °C (50 °F))

- 250 mbar a/25 kPa a/3.6 psi a
- 1300 mbar a/130 kPa a/18.8 psi a
- 5 bar a/500 kPa a/72.5 psi a
- 30 bar a/3000 kPa a/435 psi a
- 100 bar a/10 MPa a/1450 psi a
- 160 bar a/16 MPa a/2321 psi a
- 400 bar a/40 MPa a/5802 psi a
- 700 bar a/70 MPa a/10152 psi a

- $\leq (0.15 \cdot r + 0.1)\%$
- $\leq (0.08 \cdot r + 0.16)\%$

Long-term stability at ± 30 °C (± 54 °F)

In 5 years $\leq (0.25 \cdot r)\%$

Step response time T_{63} (without electrical damping)

Approx. 0.2 s

Effect of mounting position (in pressure per change of angle)

≤ 0.7 mbar/0.07 kPa/0.001015 psi per 10° incline
 (zero point correction is possible with position error compensation)

Effect of auxiliary power (in % per voltage change)

0.005% per 1 V

Rated conditions

Temperature of medium

- Measuring cell with silicone oil filling
 - Measuring cell 30 bar (435 psi), PN 420
- Measuring cell with inert oil
 - Measuring cell 30 bar (435 psi), PN 420
- Measuring cell with FDA-compliant oil
- In conjunction with dust explosion protection

- 40 ... +100 °C (-40 ... +212 °F)
- 20 ... +85 °C (-4 ... +185 °F)
- 20 ... +100 °C (-4 ... +212 °F)
- 20 ... +85 °C (-4 ... +185 °F)
- 10 ... +100 °C (14 ... +212 °F)
- 40 ... +85 °C (-4 ... +185 °F)

Ambient conditions

- Ambient temperature/enclosure
 - Measuring cell with silicone oil filling
 - Measuring cell with silicone oil filling, measuring cell 30 bar (435 psi), PN 420
 - Measuring cell with inert oil
 - Measuring cell with FDA-compliant oil
 - Display
- Storage temperature
- Climatic class in accordance with IEC 60721-3-4
- Degree of protection
 - According to IEC 60529
 - According to NEMA 250
- Electromagnetic compatibility
 - Emitted interference and interference immunity

- Observe the temperature class in areas subject to explosion hazard.
- 40 ... +85 °C (-40 ... +185 °F)
- 20 ... +85 °C (-4 ... +185 °F)
- 20 ... +85 °C (-4 ... +185 °F)
- 10 ... +85 °C (14 ... +185 °F)
- 20 ... +80 °C (-4 ... +176 °F)
- 50 ... +85 °C (-58 ... +185 °F); with FDA-compliant oil: -20 ... +85 °C (-4 ... +185 °F)
- 4K4H
- IP66, IP68
- Type 4X
- According to IEC 61326 and NAMUR NE 21

Design

Weight

Approx. 3.9 kg (8.5 lb) with aluminum enclosure
 Approx. 5.8 kg (12.7 lb) with stainless steel enclosure

Material

- Wetted parts materials
 - Seal diaphragm
 - Process flanges and sealing plugs
 - O-ring
- Non-wetted parts materials
 - Electronics housing
 - Pressure flange screws
 - Mounting bracket

- Stainless steel, mat. no. 1.4404/316L, Alloy C276, mat. no. 2.4819, Monel, mat. no. 2.4360, tantalum or gold
- Stainless steel, mat. no. 1.4408 to PN 160, mat. no. 1.4571/316Ti for PN 420, Alloy C22, 2.4602 or Monel, mat. no. 2.4360
- FPM (Viton) or optionally: PTFE, FEP, FEPM and NBR
- Low-copper die-cast aluminum GD-AISI 12 or stainless steel precision casting, mat. no. 1.4409/ CF-3M
- Standard: Powder coating with polyurethane
 - Option: 2 coats: Coat 1: epoxy-based; coat 2: Polyurethane
- Stainless steel type plate (1.4404/316L)
- Stainless steel ISO 3506-1 A4-70
- Steel, electrogalvanized steel, or stainless steel

Process connection

$\frac{1}{2}$ -18 NPT female thread and flat connection with 7/16-20 UNF fastening screw thread in accordance with EN 61518 or M10 fastening screw thread in accordance with DIN 19213 (M12 for PN 420 (MWP 6092 psi))

Electrical connection

- Screw terminals
- Cable entry via the following screwed glands:
 - M20 x 1.5
 - $\frac{1}{2}$ -14 NPT
 - Han 7D/Han 8D device plug¹⁾
 - M12 device plug

Pressure Measurement

Transmitters for applications with advanced requirements (Advanced)

SITRANS P320/P420

for absolute pressure (differential pressure series)

SITRANS P320 / SITRANS P420 for absolute pressure (differential pressure series)

Displays and controls

Keys	4 keys for operation directly on the device
Display	<ul style="list-style-type: none"> • With or without integrated display (optional) • Cover with inspection window (optional)

Auxiliary power U_H

Terminal voltage on pressure transmitter	10.5 ... 45 V DC 10.5 ... 30 V DC in intrinsically safe mode
Ripple	$U_{SS} \leq 0.2 \text{ V}$ (47 ... 125 Hz)
Noise	$U_{eff} \leq 1.2 \text{ mV}$ (0.5 ... 10 kHz)
Auxiliary power	–
Separate supply voltage	–

Certificates and approvals

Classification according to pressure equipment directive (PED 2014/68/EU)	For gases of fluid group 1 and liquids of fluid group 1; complies with requirements of article 4, paragraph 3 (sound engineering practice)
Drinking water	
• WRAS (England)	Available soon
• ACS (France)	Available soon
• DVGW (Germany)	Available soon
• NSF (USA)	Available soon
CRN (Canada)	Available soon
Explosion protection acc. to NEPSI (China)	Available soon
Explosion protection acc. to INMETRO (Brazil)	Available soon
BAM (Germany), oxygen expenditures	Available soon
Explosion protection	
• Intrinsic safety "i"	
- Marking	II 1/2 G Ex ia/ib IIC T4/T6 Ga/Gb
- Permissible ambient temperature	-40 ... +80 °C (-40 ... +176 °F) temperature class T4 -40 ... +70 °C (-40 ... +158 °F) temperature class T6
- Permissible temperature of measuring medium	-40 ... +100 °C (-40 ... +212 °F) temperature class T4 -40 ... +70 °C (-40 ... +158 °F) temperature class T6
- Connection	To certified intrinsically safe circuits with peak values: $U_i = 30 \text{ V}$, $I_i = 101 \text{ mA}$, $P_i = 760 \text{ mW}$ $U_i = 29 \text{ V}$, $I_i = 110 \text{ mA}$, $P_i = 800 \text{ mW}$ $L_i = 0.24 \text{ } \mu\text{H}/C_i = 3.29 \text{ nF}$
- Effective internal inductance/capacitance	
• Flameproof enclosure "d"	
- Marking	Ex II 1/2 G Ex ia/db IIC T4/T6 Ga/Gb
- Permissible ambient temperature	-40 ... +80 °C (-40 ... +176 °F) temperature class T4 -40 ... +70 °C (-40 ... +158 °F) temperature class T6
- Permissible temperature of measuring medium	-40 ... +100 °C (-40 ... +212 °F) temperature class T4 -40 ... +70 °C (-40 ... +158 °F) temperature class T6
- Connection	To a circuit with the operating values: $U_n = 10.5 \text{ to } 45 \text{ V}$, $4 \text{ ... } 20 \text{ mA}$
• Dust explosion protection for Zone 20, 21, 22	
- Marking	Ex II 1D Ex tb IIIC T120 °C Da Ex II 2D Ex tb IIIC T120 °C Db Ex II 3D Ex tc IIIC T120 °C Dc
- Permissible ambient temperature	-40 ... +80 °C (-40 ... +176 °F)
- Permissible temperature of measuring medium	-40 ... +100 °C (-40 ... +212 °F)
- Max. surface temperature	120 °C (248 °F)
- Connection	To a circuit with the operating values: $U_n = 10.5 \text{ to } 45 \text{ V}$, $4 \text{ ... } 20 \text{ mA}$
• Dust explosion protection for Zone 20, 21, 22	
- Marking	Ex II 1D Ex ia IIIC T120 °C Da Ex II 2D Ex ib IIIC T120 °C Db Ex II 3D Ex ic IIIC T120 °C Dc
- Permissible ambient temperature	-40 ... +80 °C (-40 ... +176 °F)
- Permissible temperature of measuring medium	-40 ... +100 °C (-40 ... +212 °F)
- Connection	To certified intrinsically safe circuits with the peak values: $U_i = 30 \text{ V}$, $I_i = 101 \text{ mA}$, $P_i = 760 \text{ mW}$ $U_i = 29 \text{ V}$, $I_i = 110 \text{ mA}$, $P_i = 800 \text{ mW}$ $L_i = 0.24 \text{ } \mu\text{H}/C_i = 3.29 \text{ nF}$
- Effective internal inductance/capacitance	

Pressure Measurement

Transmitters for applications with advanced requirements (Advanced)

SITRANS P320/P420

for absolute pressure (differential pressure series)

1

SITRANS P320 / SITRANS P420 for absolute pressure (differential pressure series)

<ul style="list-style-type: none"> • Type of protection for Zone 2 <ul style="list-style-type: none"> - Marking - Permissible ambient temperature "ec" - Permissible ambient temperature "ic" - Permissible temperature of measuring medium - "ec" connection - "ic" connection • Explosion protection acc. to FM <ul style="list-style-type: none"> - Marking (XP/DIP) or IS; NI; S • Explosion protection according to CSA <ul style="list-style-type: none"> - Marking (XP/DIP) or (IS) 	<p>Ex II 3G Ex ec IIC T4/T6 Gc Ex II 3G Ex ic IIC T4/T6 Gc</p> <p>-40 ... +80 °C (-40 ... +176 °F) temperature class T4 -40 ... +40 °C (-40 ... +104 °F) temperature class T6 -40 ... +80 °C (-40 ... +176 °F) temperature class T4 -40 ... +80 °C (-40 ... +176 °F) temperature class T6 -40 ... +100 °C (-40 ... +212 °F) temperature class T4 -40 ... +70 °C (-40 ... +158 °F) temperature class T6</p> <p>To a circuit with the operating values: $U_n = 10.5$ to 30 V, 4 ... 20 mA</p> <p>To certified intrinsically safe circuits with the peak values: $U_i = 30$ V, $I_i = 101$ mA, $P_i = 760$ mW $U_i = 29$ V, $I_i = 110$ mA, $P_i = 800$ mW</p> <p>Effective internal inductance/capacitance: $L_i = 0.24$ μH/$C_i = 3.29$ nF</p> <p>Available soon CL I, DIV 1, GP ABCD T4 ... T6; CL II, DIV 1, GP EFG; CL III; Ex ia IIC T4 ... T6; CL I, DIV 2, GP ABCD T4 ... T6; CL II, DIV 2, GP FG; CL III</p> <p>Available soon CL I, DIV 1, GP ABCD T4 ... T6; CL II, DIV 1, GP EFG; CL III; Ex ia IIC T4 ... T6; CL I, DIV 2, GP ABCD T4 ... T6; CL II, DIV 2, GP FG; CL III</p>
--	--

¹⁾ Han 8D is identical to Han 8U.

HART communication

HART	230 ... 1100 Ω
Protocol	HART 7
Software for computer	SIMATIC PDM

Pressure Measurement

Transmitters for applications with advanced requirements (Advanced)

SITRANS P320/P420

for absolute pressure (differential pressure series)

1

Selection and ordering data

	Article No.
Pressure transmitters for absolute pressure (differential pressure series)	
SITRANS P320	7MF033
SITRANS P420	7MF043
Click on the Article no. for the online configuration in the PIA Life Cycle Portal.	
Communication	0
HART, 4 ... 20 mA	
Measuring cell filling	1 3 4
Silicone oil	
Inert liquid	
Neobee oil	
Maximum measuring span	G L P R U
250 mbar a (100.5 inH ₂ O a)	
1 300 mbar a (522 inH ₂ O a)	
5000 mbar a (72.5 psi a)	
30 bar a (435 psi a)	
100 bar a (1450 psi a)	
Process connection	Q R S T V W
Oval flange, mounting thread: 7/16"-20 UNF (IEC 61518)	
Oval flange, mounting thread: M10 (DIN 19213)	
Oval flange, mounting thread: 7/16"-20 UNF (IEC 61518) with lateral ventilation	
Oval flange, mounting thread: M10 (DIN 19213) with lateral ventilation	
Version for diaphragm seal with mounting thread 7/16"-20 UNF (IEC 61518)	
Version for diaphragm seal with mounting thread M10 (DIN 19213)	
Wetted parts materials: Process connection, seal diaphragm	0 1 2 4 6 8
Stainless steel 316L/1.4404, stainless steel 316L/1.4404	
Stainless steel 316L/1.4404, alloy C276/2.4819	
Alloy C22/2.4602, alloy C276/2.4819	
Tantalum/tantalum	
Monel 00/2.4360, Monel 400/2.4360	
Stainless steel 316L/1.4404, gold-plated	
Non-wetted parts materials	1 2
Die-cast aluminum	
Stainless steel precision casting CF3M/1.4409 similar to 316L	
Enclosure	5
Dual chamber device	
Type of protection	A B C D L M S T
Without Ex	
Intrinsic safety	
Flameproof enclosure	
Flameproof enclosure, intrinsic safety	
Dust protection by enclosure Zone 21/22 (DIP), increased safety Zone 2	
Dust protection by enclosure Zone 20/21/22 (DIP), increased safety Zone 2	
Combination of options B, C and L (zone model)	
Combination of options B, C and M (zone model, Class Division)	
Electrical connections/cable entries	F M
Thread for cable gland	
• 2 x M20 x 1.5	
• 2 x 1/2"-14 NPT	
Local operation/display	0 1 2
Without display (cover closed)	
With display (cover closed)	
With display (cover with glass pane)	

Pressure Measurement

Transmitters for applications with advanced requirements (Advanced)

SITRANS P320/P420

for absolute pressure (differential pressure series)

1

Selection and ordering data

<i>Options</i>	Order code	<i>Options</i>	Order code
Add "-Z" to article no. and specify order code.			
Cable glands included		Device options	
Plastic	A00	PDF file with device settings	D10
Metal	A01	Double layer coating (epoxy resin and polyurethane) 120 µm of enclosure and cover	D20
Stainless steel	A02	FVMQ enclosure sealing	D21
Stainless steel 316L/1.4404	A03	IP66/IP68 degree of protection (not for M12 and Han device plugs)	D30
CMP, for XP devices	A10	TAG label empty	D40
CAPRI ADE 4F, CuZn, cable inner diameter 7 ... 12 mm, cable outer diameter 10 ... 16 mm	A11	Without labeling of the measuring range on the TAG label	D41
CAPRI ADE 4F, stainless steel, cable inner diameter 7 ... 12 mm, cable outer diameter 10 ... 16 mm	A12	Stainless steel Ex plate 1.4404/316L	D42
Han device plug mounted left		Increase of pressure stage from PN 420 to PN 500	D50
Han 7D device plug (plastic, straight)	A30	Overvoltage protection up to 6 kV (external)	D71
Han 7D device plug (plastic, angled)	A31	Adhesive labels on transport packaging (supplied by customer)	D90
Han 7D device plug (metal, straight)	A32		
Han 7D device plug (metal, angled)	A33	General approval without Ex approval	
Han 8D device plug (plastic, straight)	A34	Worldwide (CE, RCM) except EAC, FM, CSA, KCC	E00
Han 8D device plug (plastic, angled)	A35	Worldwide (CE, RCM, EAC, FM, CSA, KCC)	E01
Han 8D device plug (metal, straight)	A36	CSA	E06
Han 8D device plug (metal, angled)	A37	EAC	E07
		FM	E08
Cable socket included		KCC	E09
Plastic, for Han 7D/8D device plugs	A40	UL	E10
Metal, for Han 7D/8D device plugs	A41		
M12 device plug mounted left		Explosion protection approvals	
Stainless steel, without cable socket	A62	ATEX (Europe)	E20
Stainless steel, with cable socket	A63	CSA (USA and Canada)	E21
		FM (USA and Canada)	E22
Cable entry/connector mounting		IECEX (Worldwide)	E23
2x sealing plugs M20 x 1.5, IP66/68 installed on both sides	A90	EACEx (GOST-R, -K, -B)	E24
2x sealing plugs ½-14 NPT, IP66/68 installed on both sides	A91	INMETRO (Brazil)	E25
Cable gland/connector mounted left	A97	KCs (Korea)	E26
Cable gland/connector mounted on right	A99	NEPSI (China)	E27
		PESO (India)	E28
Nameplate labeling		TIIS Hazardous (Japan)	E29
German (bar)	B11	UKR Sepro (Ukraine)	E30
French (bar)	B12	ATEX (Europe) and IECEX (Worldwide)	E47
Spanish (bar)	B13	CSA (Canada) and FM (USA)	E48
Italian (bar)	B14	ATEX (Europe) and IECEX (Worldwide) + CSA (Canada) and FM (USA)	E49
Chinese (bar)	B15		
Russian (bar)	B16	Marine approvals	
English (psi)	B20	DNV-GL (Det Norske Veritas/Germanischer Lloyd)	E50
Chinese (Pa)	B35	LR (Lloyds Register)	E51
		BV (Bureau Veritas)	E52
Certificates		ABS (American Bureau of Shipping)	E53
Quality test certificate, 5-point factory calibration (IEC 60770-2)	C11	KR (Korean Register of Shipping)	E56
Acceptance certificate (EN 10204-3.1) - Material of pressurized and wetted parts	C12	RINA (Registro Italiano Navale)	E57
Test report - NACE (MR 0103-2012 and MR 0175-2009)	C13	CCS (China Classification Society)	E58
Test report (EN 10204-2.2) - Wetted parts	C14		
Acceptance certificate (EN 10204-3.1) - PMI test of pressurized and wetted parts	C15	Country-specific approvals	
		CRN approval Canada (Canadian Registration Number)	E60
Certificates for functional safety			
Functional safety (IEC 61508) - SIL2/3	C20		

Pressure Measurement

Transmitters for applications with advanced requirements (Advanced)

SITRANS P320/P420

for absolute pressure (differential pressure series)

Options	Order code	Options	Order code
Special approvals		Process flange options	
Oxygen application (with inert liquid, max. 100 bar (1 450 psi) at 60° C (140 °F))	E80	Process flanges for vertical differential pressure lines (half process flange)	K81
Dual seal	E81	Process flanges (+) - side front	K82
WRC / WRAS (drinking water); only with pressure cap O-rings made of EPDM	E83	Process flange screws, process flange nuts, material Monel 400/2.4360	K83
NSF61 (drinking water)	E84	Valve ¼-18 NPT, material same as process flanges	K84
ACS (drinking water)	E85	Valve mounted on the side, measured medium: Gas	K85
Mounting bracket		Oval flange enclosed, gasket PTFE + mounting screws	K86
Steel, galvanized	H01	Pneumatic blocks	
Stainless steel 1.4301/304	H02	With mounted pneumatic block (3-way) 7MF9411-5BA, PTFE sealing rings, chrome-plated steel screws and pressure test certified in test report (EN 10204-2.2)	U01
Stainless steel 1.4404/316L	H03	With mounted pneumatic block (3-way) 7MF9411-5BA, PTFE sealing rings, stainless steel screws and pressure test certified in test report (EN 10204-2.2)	U02
Process flanges; screw plug with vent valve		With mounted pneumatic block (5-way) 7MF9411-5CA, PTFE sealing rings, chrome-plated steel screws and pressure test certified in test report (EN 10204-2.2)	U03
Welded in on right	J08	With mounted pneumatic block (5-way) 7MF9411-5CA, PTFE sealing rings, stainless steel screws and pressure test certified in test report (EN 10204-2.2)	U04
Welded in on left	J09		
Glued in on right	J10		
Glued in on left	J11		
Flange connections with flange EN 1092-1			
Form B1			
• DN 25 PN 40, stainless steel 1.4571/316Ti	J70		
• DN 50 PN 40, stainless steel 1.4571/316Ti	J71		
• DN 80 PN 40, stainless steel 1.4571/316Ti	J72		
• DN 15 PN 40, stainless steel 1.4571/316Ti	J78		
Form C			
• DN 25 PN 40, stainless steel 1.4571/316Ti	J73		
• DN 50 PN 40, stainless steel 1.4571/316Ti	J74		
• DN 80 PN 40, stainless steel 1.4571/316Ti	J75		
Flange connection options			
Flange connection and temperature extension	J76		
Flange connection with epoxy resin coating	J77		
Process flanges; special materials			
Reserved for 7MF7: without process flanges, without screws, without gaskets	K00		
Process flange material alloy C4/2.4610	K01		
Process flange material Monel 400/2.4360	K02		
Process connection material PVDF, on the side ½-14 NPT	K05		
Process flanges/process connection material PVDF, flange on the side EN 1092-1 Form B1 DN 25 PN 40, MAWP 4 bar	K06		
Process flanges/process connection material PVDF, flange on the side EN 1092-1 Form B1 DN 40 PN 40, MAWP 4 bar	K07		
Process flanges; process connection option			
Process flange with process connection G½ welded on	K20		
Process connection (oval flange) NAM (ASTAVA)	K21		
Process flanges chambered with gaskets			
1x chambered, graphite	K40		
1x chambered, PTFE	K41		
2x chambered, PTFE	K42		
Process flanges, gaskets (instead of standard gaskets FKM (FPM))			
O-ring, process flanges, PTFE	K50		
O-ring, process flanges, FEP (with silicone core, approved for food)	K51		
O-ring, process flanges, FFKM (FFPM)	K52		
O-ring, process flanges, NBR	K53		
O-ring, process flanges, EPDM	K54		

Selection and ordering data

<i>Customer-specific device settings</i>	Order code
Add "-Z" to article no., specify order code and plain text or drop-down list selection.	
Measuring span Start of scale value (max. 5 characters), full scale value (max. 5 characters), unit [mbar, bar, kPa, MPa, psi, ...], example: -0.5 ... 10.5 psi Input field 1 and input field 2: max. 5 characters and numbers only; decimal places as dot (comma is automatically converted to dot). Drop-down list: Pa, MPa, kPa, hPa, bar, mbar, psi, g/cm ² , kg/cm ² , kgf/cm ² , inH ₂ O, inH ₂ O (4°C), ftH ₂ O, mmH ₂ O, mmH ₂ O (4°C), mH ₂ O (4°C), mmHg, inHg, atm, torr	Y01
TAG (on stainless steel plate and device parameters, max. 32 characters) Input field: Free text, max. 32 characters	Y15
Measuring point description (on stainless steel plate and device parameters, max. 32 characters) Input field: Free text, max. 32 characters	Y16
TAG short (device parameters, max. 8 characters) Input field: Free text, max. 8 characters	Y17
Local display [Pressure, Percent], reference [None, Absolute, Relative], example: Pressure gauge Drop-down list: Percent, pressure unit, pressure unit abs., pressure unit gauge	Y21
Local display Scaling with standard units [m³/s, l/s, m, inch, ...], example 1 ... 5 m Input field 1 and input field 2: max. 5 characters and numbers only; decimal places as dot (comma is automatically converted to dot). Drop-down list: m, cm, mm, in, ft, m ³ , l, hl, in ³ , ft ³ , yd ³ , gal, gal (UK), bu, bbl, bbl (US), SCF, Nm ³ , NI.	Y22
Local display Scaling with user-specific units (max. 12 characters), example 1 ... 5 m Input field 1 and input field 2: max. 5 characters and numbers only; decimal places as dot (comma is automatically converted to dot). Input field 3: Free text, max. 8 characters	Y23
Saturation limits instead of 3.8 ... 20.5 mA, example: 3.8 ... 22.0 mA Drop-down list 1: 3.9, 4 Drop-down list 2: 20.8, 22	Y30
Fault current instead of 3.6 mA [22.5 mA, 22.8 mA] Drop-down list: 3.75; 21.75; 22.5; 22.6	Y31
Damping in seconds instead of 2 s (0.0 ... 100.0 s) Input field: max. 4 characters and numbers only; decimal places as dot (comma is automatically converted to dot); min. value = 0; max. value = 100.	Y32
ID number of special version Input field: max. 4 characters and only natural numbers from 0 ... 9999	Y99

Pressure Measurement

Transmitters for applications with advanced requirements (Advanced)
SITRANS P320/P420

for absolute pressure (differential pressure series)

Dimensional drawings

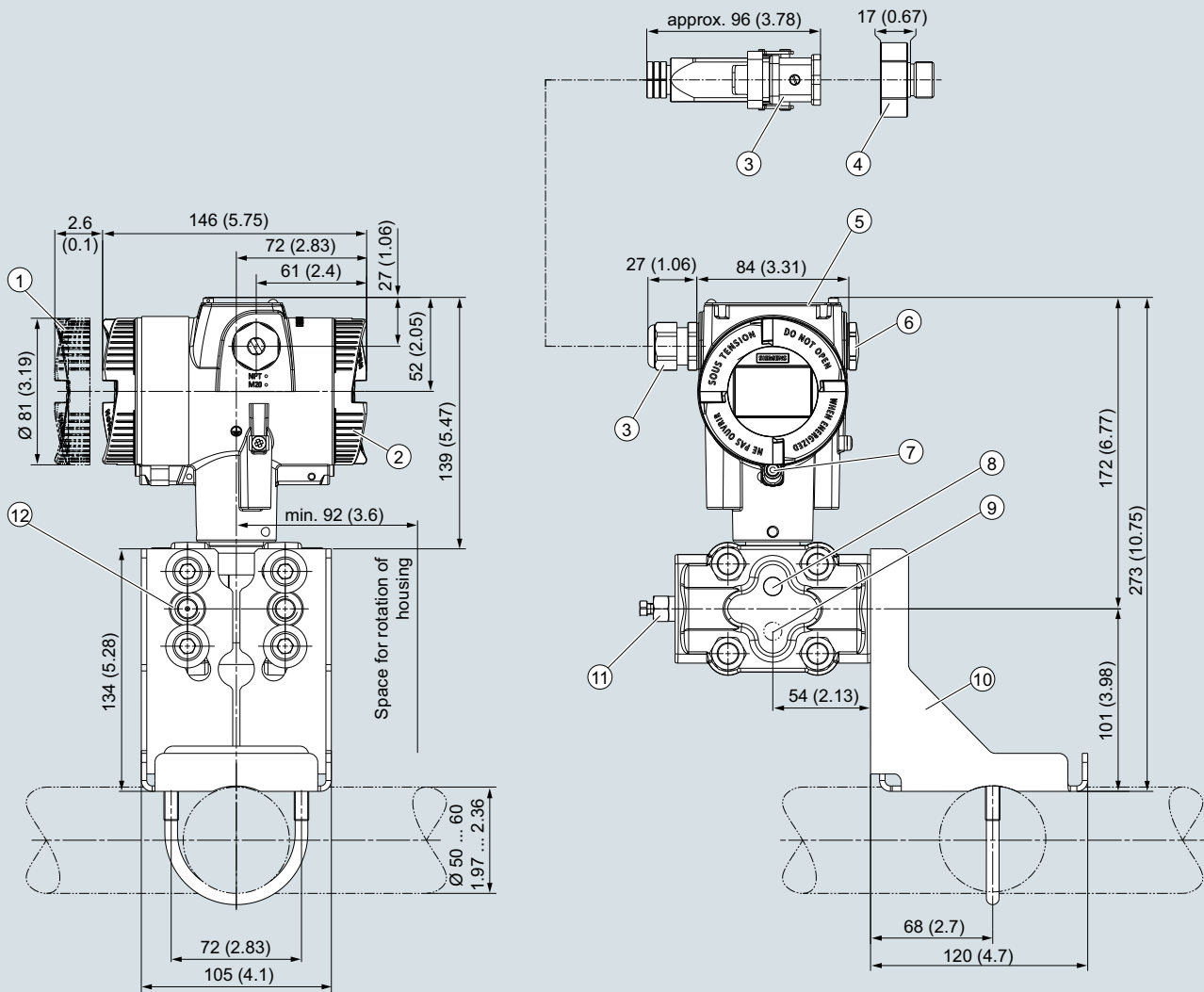

- | | |
|--|---|
| ① Electronic side, display
(longer overall length for cover with window) ¹⁾ | ⑥ Blanking plug |
| ② Terminal side | ⑦ Screw cover - safety bracket
(only for type of protection "Explosion-proof enclosure") |
| ③ Electrical connection:
screw gland M20 x 1,5 ³⁾ or screw gland ½-14 NPT or
Han 7D/Han 8D ^{2) 3)} device plug or M12 device plug ^{2) 3)} | ⑧ Lateral venting for liquid measurement (Standard) |
| ④ Harting adapter | ⑨ Lateral venting for gas measurement (suffix K85) |
| ⑤ Cover over buttons and nameplate with general information | ⑩ Mounting bracket (option) |
| | ⑪ Sealing screw with valve (option) |
| | ⑫ Process connection: ¼-18 NPT (IEC 61518) |

¹⁾ In addition, allow approx. 22 mm (0.87 inch) for the thread length when removing the covers

²⁾ Not with type of protection "Explosion-proof enclosure"

³⁾ Not with type of protection "FM + CSA" [is + XP]"

SITRANS P320/P420 pressure transmitter for absolute pressure (differential pressure series), dimensions in mm (inch)

Pressure Measurement

Transmitters for applications with advanced requirements (Advanced)

SITRANS P320/P420

for differential pressure and flow

1

Technical specifications**SITRANS P320 / SITRANS P420 for differential pressure and flow****Input**

Measured variable	Differential pressure and flow		
Span (infinitely adjustable) and maximum operating pressure (pursuant to Pressure Equipment Directive 2014/68/EU)	Span	Max. permissible operating pressure MAWP (PS)	Maximum permissible test pressure
	1 ... 20 mbar	160 bar	240 bar
	0.1 ... 2 kPa	16 MPa	24 MPa
	0.4019 ... 8.037 inH ₂ O	2320 psi	3480 psi
	1 ... 60 mbar	160 bar	240 bar
	0.1 ... 6 kPa	16 MPa	24 MPa
	0.4019 ... 24.11 inH ₂ O	2320 psi	3480 psi
	2.5 ... 250 mbar	160 bar	240 bar
	0.2 ... 25 kPa	16 MPa	24 MPa
	1.005 ... 100.5 inH ₂ O	2320 psi	3480 psi
	6 ... 600 mbar	160 bar	240 bar
	0.6 ... 60 kPa	16 MPa	24 MPa
	2.41 ... 241.1 inH ₂ O	2320 psi	3480 psi
	16 ... 1600 mbar	160 bar	240 bar
	1.6 ... 160 kPa	16 MPa	24 MPa
	6.43 ... 643 inH ₂ O	2320 psi	3480 psi
	50 ... 5000 mbar	160 bar	240 bar
	5 ... 500 kPa	16 MPa	24 MPa
	20.09 ... 2009 inH ₂ O	2320 psi	3480 psi
	0.3 ... 30 bar	160 bar	240 bar
	0.03 ... 3 MPa	16 MPa	24 MPa
	4.35 ... 435 psi	2320 psi	3480 psi
	2.5 ... 250 mbar	420 bar	630 bar
	0.25 ... 25 kPa	42 MPa	63 MPa
	1.005 ... 100.5 inH ₂ O	6092 psi	9137 psi
	6 ... 600 mbar	420 bar	630 bar
	0.6 ... 60 kPa	42 MPa	63 MPa
	2.41 ... 241.1 inH ₂ O	6092 psi	9137 psi
	16 ... 1600 mbar	420 bar	630 bar
	1.6 ... 160 kPa	42 MPa	63 MPa
	6.43 ... 643 inH ₂ O	6092 psi	9137 psi
	50 ... 5000 mbar	420 bar	630 bar
	5 ... 500 kPa	42 MPa	63 MPa
	20.09 ... 2009 inH ₂ O	6092 psi	9137 psi
	0.3 ... 30 bar	420 bar	630 bar
	0.03 ... 3 MPa	42 MPa	63 MPa
	4.35 ... 435 psi	6092 psi	9137 psi
Measuring limits			
• Low measuring limit			
- Measuring cell with silicone oil filling			
- Measuring cell with inert liquid			
	-100% of maximum measuring range or 30 mbar a /3 kPa a /0.44 psi a		
	For process temperature -20 °C < ϑ ≤ +60 °C (-4 °F < ϑ ≤ +140 °F)		-100% of maximum measuring range or 30 mbar a /3 kPa a /0.44 psi a
	For process temperature 60 °C < ϑ ≤ +100 °C (max. 85 °C for measuring cell 30 bar with PN 420) (140 °F < ϑ ≤ +212 °F (max. 185 °F for measuring cell 435 psi))		-100% of maximum measuring range or 30 mbar a /3 kPa a /0.44 psi a 30 mbar a + 20 mbar a · (ϑ - 60 °C)/°C 3 kPa a + 2 kPa a · (ϑ - 60 °C)/°C 0.44 psi a + 0.29 psi a · (ϑ - 140 °F)/°F
- Measuring cell with FDA-compliant oil			
	For process temperature -10 °C < ϑ ≤ +100 °C (-14 °F < ϑ ≤ +212 °F)		-100% of maximum measuring range or 100 mbar a /10 kPa a /14.5 psi a
• Upper measuring limit			100% of the max. measuring span (for oxygen measurement max. 100 bar/10 MPa/ 1450 psi and 60 °C (140 °F) ambient temperature/process temperature)
• Start of scale			Between the measuring limits (infinitely adjustable)

Pressure Measurement

Transmitters for applications with advanced requirements (Advanced)

SITRANS P320/P420

for differential pressure and flow

SITRANS P320 / SITRANS P420 for differential pressure and flow

Output	HART
Output signal	4 ... 20 mA
<ul style="list-style-type: none"> Low saturation limit (infinitely adjustable) High saturation limit (infinitely adjustable) Ripple (without HART communication) 	3.55 mA, factory preset to 3.8 mA 22.8 mA, factory-set to 20.5 mA or optionally 22.0 mA $I_{pp} \leq 0.5\%$ of max. output current
Adjustable damping	0 ... 100 s, continuously adjustable over remote operation
<ul style="list-style-type: none"> Current transmitter Failure signal 	0 ... 100 s, in increments of 0.1 s, adjustable over display 3.55 ... 22.8 mA 3.55 ... 22.8 mA
Load	Resistor R [Ω]
<ul style="list-style-type: none"> Without HART communication With HART communication 	$R = (U_H - 10.5 \text{ V}) / 22.8 \text{ mA}$, U_H : Power supply in V $R = 230 \dots 1100 \Omega$ (HART communicator (handheld)) $R = 230 \dots 500 \Omega$ (SIMATIC PDM)
Characteristic curve	<ul style="list-style-type: none"> Linearly increasing or linearly decreasing Linear increase or decrease or according to the square root (only for differential pressure and flow)
Physical bus	-
Polarity-independent	-
Measuring accuracy	
Reference conditions	<ul style="list-style-type: none"> According to EN 60770-1 Rising characteristic curve Start of scale value 0 bar/kPa/psi Seal diaphragm stainless steel Measuring cell with silicone oil filling Room temperature 25 °C (77 °F)
Conformity error at limit point setting, including hysteresis and repeatability	
Measuring span ratio r (spread, Turn-Down)	r = maximum measuring span/set measuring span or nominal measuring range
<ul style="list-style-type: none"> Linear characteristic 	
- 20 mbar/2 kPa/0.29 psi	$r \leq 5$: $\leq 0.075\%$ $5 < r \leq 20$: $\leq (0.005 \cdot r + 0.05)\%$
- 60 mbar/6 kPa/0.87 psi	$r \leq 5$: $\leq 0.075\%$ $5 < r \leq 60$: $\leq (0.005 \cdot r + 0.05)\%$
- 250 mbar/25 kPa/3.63 psi 600 mbar/60 kPa/8.7 psi 1600 mbar/160 MPa/23.21 psi 5 bar/500 kPa/72.5 psi 30 bar/3 MPa/435 psi	$r \leq 5$: $\leq 0.065\%$ (SITRANS P320) $5 < r \leq 100$: $\leq (0.004 \cdot r + 0.045)\%$ (SITRANS P320)
- 250 mbar/25 kPa/3.63 psi (PN 160) 600 mbar/60 kPa/8.7 psi 1600 mbar/160 MPa/23.21 psi 5 bar/500 kPa/72.5 psi 30 bar/3 MPa/435 psi	$r \leq 5$: $\leq 0.04\%$ (SITRANS P420) $5 < r \leq 100$: $\leq (0.004 \cdot r + 0.045)\%$ (SITRANS P420)
- 250 mbar/25 kPa/3.63 psi (PN 420)	$r \leq 5$: $\leq 0.065\%$ (SITRANS P420)
<ul style="list-style-type: none"> Square-rooted characteristic (flow > 50%) 	
- 20 mbar/2 kPa/0.29 psi	$r \leq 5$: $\leq 0.075\%$ $5 < r \leq 20$: $\leq (0.005 \cdot r + 0.05)\%$
- 60 mbar/6 kPa/0.87 psi	$r \leq 5$: $\leq 0.075\%$ $5 < r \leq 60$: $\leq (0.005 \cdot r + 0.05)\%$
- 250 mbar/25 kPa/3.63 psi 600 mbar/60 kPa/8.7 psi 1600 mbar/160 MPa/23.21 psi 5 bar/500 kPa/72.5 psi 30 bar/3 MPa/435 psi	$r \leq 5$: $\leq 0.065\%$ (SITRANS P320) $\leq 0.04\%$ (SITRANS P420) $5 < r \leq 100$: $\leq (0.004 \cdot r + 0.045)\%$
<ul style="list-style-type: none"> Square-rooted characteristic (flow 25 ... 50%) 	
- 20 mbar/2 kPa/0.29 psi	$r \leq 5$: $\leq 0.15\%$ $5 < r \leq 20$: $\leq (0.01 \cdot r + 0.1)\%$
- 60 mbar/6 kPa/0.87 psi	$r \leq 5$: $\leq 0.15\%$ $5 < r \leq 60$: $\leq (0.01 \cdot r + 0.1)\%$
- 250 mbar/25 kPa/3.63 psi 600 mbar/60 kPa/8.7 psi 1600 mbar/160 MPa/23.21 psi 5 bar/500 kPa/72.5 psi 30 bar/3 MPa/435 psi	$r \leq 5$: $\leq 0.13\%$ (SITRANS P320) $\leq 0.008\%$ (SITRANS P420) $5 < r \leq 100$: $\leq (0.008 \cdot r + 0.09)\%$

Pressure Measurement

Transmitters for applications with advanced requirements (Advanced)

SITRANS P320/P420

for differential pressure and flow

1

SITRANS P320 / SITRANS P420 for differential pressure and flow

Influence of ambient temperature (in % per 28 °C (50 °F))

- 20 mbar/2 kPa/0.29 psi	$\leq (0.15 \cdot r + 0.1)\%$
- 60 mbar/6 kPa/0.87 psi	$\leq (0.075 \cdot r + 0.1)\%$
- 250 mbar/25 kPa/3.63 psi	$\leq (0.025 \cdot r + 0.125)\%$ (SITRANS P320)
600 mbar/60 kPa/8.7 psi	
1600 mbar/160 MPa/23.21 psi	
5 bar/500 kPa/72.5 psi	
30 bar/3 MPa/435 psi	
- 250 mbar/25 kPa/3.63 psi	$\leq (0.025 \cdot r + 0.0625)\%$ (SITRANS P420)
5 bar/500 kPa/72.5 psi	
30 bar/3 MPa/435 psi	
- 600 mbar/60 kPa/8.7 psi	$\leq (0.0125 \cdot r + 0.0625)\%$ (SITRANS P420)
1600 mbar/160 MPa/23.21 psi	
30 bar/3 MPa/435 psi	

Effect of static pressure

• on the start of scale	Zero-point correction is possible with position error compensation
- 20 mbar/2 kPa/0.29 psi	$\leq (0.15 \cdot r)\%$ per 70 bar
- 60 mbar/6 kPa/0.87 psi	$\leq (0.1 \cdot r)\%$ per 70 bar
250 mbar/25 kPa/3.63 psi	
600 mbar/60 kPa/8.7 psi	
1600 mbar/160 MPa/23.21 psi	
5 bar/500 kPa/72.5 psi	
30 bar/3 MPa/435 psi	
- 5 bar/500 kPa/72.5 psi	$\leq (0.1 \cdot r)\%$ per 70 bar (SITRANS P320)
	$\leq (0.15 \cdot r)\%$ per 70 bar (SITRANS P420)
• on the span	
- 20 mbar/2 kPa/0.29 psi	$\leq 0.2\%$ per 70 bar
- 60 mbar/6 kPa/0.87 psi	$\leq 0.1\%$ per 70 bar
250 mbar/25 kPa/3.63 psi	
600 mbar/60 kPa/8.7 psi	
1600 mbar/160 MPa/23.21 psi	
30 bar/3 MPa/435 psi	
- 5 bar/500 kPa/72.5 psi	$\leq 0.15\%$ per 70 bar (SITRANS P320)
	$\leq 0.1\%$ per 70 bar (SITRANS P420)

Long-term stability at ± 30 °C (± 54 °F)

• 20 mbar/2 kPa/0.29 psi	Static pressure max. 70 bar/7 MPa/1015 psi
• 60 mbar/6 kPa/0.87 psi	$\leq (0.2 \cdot r)\%$ per year
• 250 mbar/25 kPa/3.63 psi	In 5 years $\leq (0.25 \cdot r)\%$
600 mbar/60 kPa/8.7 psi	In 5 years $\leq (0.125 \cdot r)\%$
1600 mbar/160 MPa/23.21 psi	In 10 years $\leq (0.15 \cdot r)\%$
5 bar/500 kPa/72.5 psi	
• 30 bar/3 MPa/435 psi	In 5 years $\leq (0.25 \cdot r)\%$
	In 10 years $\leq (0.35 \cdot r)\%$

Step response time T_{63} (without electrical damping)

• 20 mbar/2 kPa/0.29 psi	Approx. 0.295 s
• 60 mbar/6 kPa/0.87 psi	Approx. 0.245 s
• 250 mbar/25 kPa/3.63 psi	Approx. 0.195 s
• 600 mbar/60 kPa/8.7 psi	Approx. 0.145 s
1600 mbar/160 MPa/23.21 psi	
5 bar/500 kPa/72.5 psi	
30 bar/3 MPa/435 psi	

Effect of mounting position (in pressure per change of angle)

 ≤ 0.7 mbar/0.07 kPa/0.028 inH₂O per 10° incline (zero point correction is possible with position error compensation)

Effect of auxiliary power (in % per voltage change)

0.005% per 1 V

Pressure Measurement

Transmitters for applications with advanced requirements (Advanced)

SITRANS P320/P420

for differential pressure and flow

1

SITRANS P320 / SITRANS P420 for differential pressure and flow

Rated conditions

Temperature of medium

- Measuring cell with silicone oil filling
 - Measuring cell 30 bar (435 psi), PN 420 -40 ... +100 °C (-40 ... +212 °F)
 - Measuring cell 30 bar (435 psi), PN 420 -20 ... +85 °C (-4 ... +185 °F)
- Measuring cell with inert oil
 - Measuring cell 30 bar (435 psi), PN 420 -20 ... +100 °C (-4 ... +212 °F)
 - Measuring cell 30 bar (435 psi), PN 420 -20 ... +85 °C (-4 ... +185 °F)
- Measuring cell with FDA-compliant oil
 - Measuring cell 30 bar (435 psi), PN 420 -10 ... +100 °C (14 ... +212 °F)
- In conjunction with dust explosion protection -40 ... +85 °C (-4 ... +185 °F)

Ambient conditions

- Ambient temperature/enclosure
 - Measuring cell with silicone oil filling Observe the temperature class in areas subject to explosion hazard.
 - Measuring cell with silicone oil filling, measuring cell 30 bar (435 psi), PN 420 -40 ... +85 °C (-40 ... +185 °F)
 - Measuring cell with inert oil -20 ... +85 °C (-4 ... +185 °F)
 - Measuring cell with inert oil -20 ... +85 °C (-4 ... +185 °F)
 - Measuring cell with FDA-compliant oil -10 ... +85 °C (14 ... +185 °F)
 - Display -20 ... +80 °C (-4 ... +176 °F)
- Storage temperature -50 ... +85 °C (-58 ... +185 °F) (with FDA-compliant oil: -20 ... +85 °C (-4 ... +185 °F))
- Climatic class in accordance with IEC 60721-3-4 4K4H
- Degree of protection
 - According to IEC 60529 IP66, IP68
 - According to NEMA 250 Type 4X
- Electromagnetic compatibility
 - Emitted interference and interference immunity According to IEC 61326 and NAMUR NE 21

Design

Weight

Approx. 3.9 kg (8.5 lb) with aluminum enclosure
Approx. 5.8 kg (12.7 lb) with stainless steel enclosure

Material

- Wetted parts materials
 - Seal diaphragm Stainless steel, mat. no. 1.4404/316L, Alloy C276, mat. no. 2.4819, Monel, mat. no. 2.4360, tantalum or gold
 - Process flanges and sealing plugs Stainless steel, mat. no. 1.4408 to PN 160, mat. no. 1.4571/316Ti for PN 420, Alloy C22, 2.4602 or Monel, mat. no. 2.4360
 - O-ring FPM (Viton) or optionally: PTFE, FEP, FEPM and NBR
- Non-wetted parts materials
 - Electronics housing
 - Low-copper die-cast aluminum GD-AISI 12 or stainless steel precision casting, mat. no. 1.4409/ CF-3M
 - Standard: Powder coating with polyurethane
 - Option: 2 coats: Coat 1: epoxy-based; coat 2: Polyurethane
 - Stainless steel type plate (1.4404/316L)
 - Pressure flange screws Stainless steel ISO 3506-1 A4-70
 - Mounting bracket Steel, electrogalvanized steel, or stainless steel

Process connection

½-18 NPT female thread and flat connection with 7/16-20 UNF fastening screw thread in accordance with EN 61518 or M10 fastening screw thread in accordance with DIN 19213 (M12 for PN 420 (MWP 6092 psi))

Electrical connection

Screw terminals
Cable entry via the following screwed glands:

- M20 x 1.5
- ½-14 NPT
- Han 7D/Han 8D device plug¹⁾
- M12 device plug

Displays and controls

Keys

4 keys for operation directly on the device

Display

- With or without integrated display (optional)
- Cover with inspection window (optional)

Auxiliary power U_H

Terminal voltage on pressure transmitter

10.5 ... 45 V DC
10.5 ... 30 V DC in intrinsically safe mode

Ripple

U_{SS} ≤ 0.2 V (47 ... 125 Hz)

Noise

U_{eff} ≤ 1.2 mV (0.5 ... 10 kHz)

Auxiliary power

–

Separate supply voltage

–

Pressure Measurement

Transmitters for applications with advanced requirements (Advanced)

SITRANS P320/P420

for differential pressure and flow

1

SITRANS P320 / SITRANS P420 for differential pressure and flow**Certificates and approvals**

Classification according to pressure equipment directive (PED 2014/68/EU)

Drinking water

- WRAS (England)
- ACS (France)
- DVGW (Germany)
- NSF (USA)

CRN (Canada)

Explosion protection acc. to NEPSI (China)

Explosion protection acc. to INMETRO (Brazil)

BAM (Germany), oxygen expenditures

Explosion protection

- Intrinsic safety "I"

- Marking

- Permissible ambient temperature

- Permissible temperature of measuring medium

- Connection

- Effective internal inductance/capacitance

- Flameproof enclosure "d"

- Marking

- Permissible ambient temperature

- Permissible temperature of measuring medium

- Connection

- Dust explosion protection for Zone 20, 21, 22

- Marking

- Permissible ambient temperature

- Permissible temperature of measuring medium

- Max. surface temperature

- Connection

- Dust explosion protection for Zone 20, 21, 22

- Marking

- Permissible ambient temperature

- Permissible temperature of measuring medium

- Connection

- Effective internal inductance/capacitance

- Type of protection for Zone 2

- Marking

- Permissible ambient temperature "ec"

- Permissible ambient temperature "ic"

- Permissible temperature of measuring medium

- "ec" connection

- "ic" connection

For gases of fluid group 1 and liquids of fluid group 1; complies with requirements of article 4, paragraph 3 (sound engineering practice)

For flow only

For gases of fluid group 1 and liquids of fluid group 1; fulfills the basic safety requirements as per article 3, paragraph 1 (appendix 1); classified as category III, module H conformity evaluation by TÜV Nord

Available soon

Available soon

Available soon

Available soon

Available soon

Available soon

Available soon

Available soon

II 1/2 G Ex ia/ib IIC T4/T6 Ga/Gb

-40 ... +80 °C (-40 ... +176 °F) temperature class T4

-40 ... +70 °C (-40 ... +158 °F) temperature class T6

-40 ... +100 °C (-40 ... +212 °F) temperature class T4

-40 ... +70 °C (-40 ... +158 °F) temperature class T6

To certified intrinsically safe circuits with peak values:

$U_i = 30 \text{ V}$, $I_i = 101 \text{ mA}$, $P_i = 760 \text{ mW}$

$U_i = 29 \text{ V}$, $I_i = 110 \text{ mA}$, $P_i = 800 \text{ mW}$

$L_i = 0.24 \text{ } \mu\text{H}/C_i = 3.29 \text{ nF}$

Ex II 1/2 G Ex ia/db IIC T4/T6 Ga/Gb

-40 ... +80 °C (-40 ... +176 °F) temperature class T4

-40 ... +70 °C (-40 ... +158 °F) temperature class T6

-40 ... +100 °C (-40 ... +212 °F) temperature class T4

-40 ... +70 °C (-40 ... +158 °F) temperature class T6

To a circuit with the operating values:

$U_n = 10.5 \text{ to } 45 \text{ V}$, $4 \text{ ... } 20 \text{ mA}$

Ex II 1D Ex tb IIIC T120 °C Da

Ex II 2D Ex tb IIIC T120 °C Db

Ex II 3D Ex tc IIIC T120 °C Dc

-40 ... +80 °C (-40 ... +176 °F)

-40 ... +100 °C (-40 ... +212 °F)

120 °C (248 °F)

To a circuit with the operating values:

$U_n = 10.5 \text{ to } 45 \text{ V}$, $4 \text{ ... } 20 \text{ mA}$

Ex II 1D Ex ia IIIC T120 °C Da

Ex II 2D Ex ib IIIC T120 °C Db

Ex II 3D Ex ic IIIC T120 °C Dc

-40 ... +80 °C (-40 ... +176 °F)

-40 ... +100 °C (-40 ... +212 °F)

To certified intrinsically safe circuits with the peak values:

$U_i = 30 \text{ V}$, $I_i = 101 \text{ mA}$, $P_i = 760 \text{ mW}$

$U_i = 29 \text{ V}$, $I_i = 110 \text{ mA}$, $P_i = 800 \text{ mW}$

$L_i = 0.24 \text{ } \mu\text{H}/C_i = 3.29 \text{ nF}$

Ex II 3G Ex ec IIC T4/T6 Gc

Ex II 3G Ex ic IIC T4/T6 Gc

-40 ... +80 °C (-40 ... +176 °F) temperature class T4

-40 ... +40 °C (-40 ... +104 °F) temperature class T6

-40 ... +80 °C (-40 ... +176 °F) temperature class T4

-40 ... +80 °C (-40 ... +176 °F) temperature class T6

-40 ... +100 °C (-40 ... +212 °F) temperature class T4

-40 ... +70 °C (-40 ... +158 °F) temperature class T6

To a circuit with the operating values:

$U_n = 10.5 \text{ to } 30 \text{ V}$, $4 \text{ ... } 20 \text{ mA}$

To certified intrinsically safe circuits with the peak values:

$U_i = 30 \text{ V}$, $I_i = 101 \text{ mA}$, $P_i = 760 \text{ mW}$

$U_i = 29 \text{ V}$, $I_i = 110 \text{ mA}$, $P_i = 800 \text{ mW}$

Effective internal inductance/capacitance:

$L_i = 0.24 \text{ } \mu\text{H}/C_i = 3.29 \text{ nF}$

Pressure Measurement

Transmitters for applications with advanced requirements (Advanced)

SITRANS P320/P420

for differential pressure and flow

SITRANS P320 / SITRANS P420 for differential pressure and flow

- | | |
|--|--|
| <ul style="list-style-type: none"> • Explosion protection acc. to FM
- Marking (XP/DIP) or IS; NI; S | <p>Available soon
CL I, DIV 1, GP ABCD T4 ... T6; CL II, DIV 1, GP EFG; CL III; Ex ia IIC T4 ... T6: CL I, DIV 2, GP ABCD T4 ... T6; CL II, DIV 2, GP FG; CL III</p> |
| <ul style="list-style-type: none"> • Explosion protection according to CSA
- Marking (XP/DIP) or (IS) | <p>Available soon
CL I, DIV 1, GP ABCD T4 ... T6; CL II, DIV 1, GP EFG; CL III; Ex ia IIC T4 ... T6: CL I, DIV 2, GP ABCD T4 ... T6; CL II, DIV 2, GP FG; CL III</p> |

HART communication

HART	230 ... 1100 Ω
Protocol	HART 7
Software for computer	SIMATIC PDM

Pressure Measurement

Transmitters for applications with advanced requirements (Advanced)

SITRANS P320/P420

for differential pressure and flow

1

Selection and ordering data

	Article No.
Pressure transmitters for differential pressure and flow, PN 160 (MAWP 2320 psi)	
SITRANS P320	7MF034 - - - - -
SITRANS P420	7MF044 - - - - -
Click on the Article no. for the online configuration in the PIA Life Cycle Portal.	
Communication	
HART, 4 ... 20 mA	0
Measuring cell filling	
Silicone oil	1
Inert liquid	3
Neobee oil	4
Maximum measuring span	
20 mbar (8.037 inH ₂ O)	B
60 mbar (24.11 inH ₂ O)	D
250 mbar (100.5 inH ₂ O)	G
600 mbar (241.1 inH ₂ O)	H
1 600 mbar (643 inH ₂ O)	M
5000 mbar (2009 inH ₂ O)	P
30 bar (435 psi)	R
Process connection	
Oval flange, mounting thread: 7/16"-20 UNF (IEC 61518)	L
Oval flange, mounting thread: M10 (PN 160) (DIN 19213)	M
Oval flange, mounting thread: 7/16"-20 UNF (IEC 61518) with lateral ventilation	N
Oval flange, mounting thread: M10 (PN 160) (DIN 19213) with lateral ventilation	P
Oval flange, mounting thread: 7/16"-20 UNF (IEC 61518)	Q
Oval flange, mounting thread: M10 (DIN 19213); only for 100 bar (1450 psi)	R
Oval flange, mounting thread: 7/16"-20 UNF (IEC 61518) with lateral ventilation	S
Oval flange, mounting thread: M10 (DIN 19213) with lateral ventilation	T
Wetted parts materials: Process connection, seal diaphragm	
Stainless steel 316L/1.4404, stainless steel 316L/1.4404	0
Stainless steel 316L/1.4404, alloy C276/2.4819	1
Alloy C22/2.4602, alloy C276/2.4819	2
Tantalum/tantalum (not in combination with maximum measuring span 20 mbar (0.29 psi) and 60 mbar (0.87 psi))	4
Monel 00/2.4360, Monel 400/2.4360 (not in combination with maximum measuring span 20 mbar (0.29 psi) and 60 mbar (0.87 psi))	6
Stainless steel 316L/1.4404, gold-plated (not in combination with maximum measuring span 20 mbar (0.29 psi) and 60 mbar (0.87 psi))	8
Non-wetted parts materials	
Die-cast aluminum	1
Stainless steel precision casting CF3M/1.4409 similar to 316L	2
Enclosure	
Dual chamber device	5
Type of protection	
Without Ex	A
Intrinsic safety	B
Flameproof enclosure	C
Flameproof enclosure, intrinsic safety	D
Dust protection by enclosure Zone 21/22 (DIP), increased safety Zone 2	L
Dust protection by enclosure Zone 20/21/22 (DIP), increased safety Zone 2	M
Combination of options B, C and L (zone model)	S
Combination of options B, C and M (zone model, Class Division)	T
Electrical connections/cable entries	
Thread for cable gland	
• 2 x M20 x 1.5	F
• 2 x 1/2-14 NPT	M

Pressure Measurement

Transmitters for applications with advanced requirements (Advanced)

SITRANS P320/P420

for differential pressure and flow

1

Article No.

Pressure transmitters for differential pressure and flow, PN 160 (MAWP 2320 psi)

SITRANS P320

7MF034 - - -

SITRANS P420

7MF044 - - -

Local operation/display

Without display (cover closed)

0

With display (cover closed)

1

With display (cover with glass pane)

2

Pressure Measurement

Transmitters for applications with advanced requirements (Advanced)

SITRANS P320/P420

for differential pressure and flow

Article No.

Pressure transmitters for differential pressure and flow, PN 420 (MAWP 6092 psi)**SITRANS P320**

↗ 7MF035 - - - - -

SITRANS P420

↗ 7MF045 - - - - -

↗ Click on the Article no. for the online configuration in the PIA Life Cycle Portal.

Communication

HART, 4 ... 20 mA

0

Measuring cell filling

Silicone oil

1

Inert liquid

3

Neobee oil

4

Maximum measuring span250 mbar (100.5 inH₂O)

G

600 mbar (241.1 inH₂O)

H

1 600 mbar (643 inH₂O)

M

5000 mbar (2009 inH₂O)

P

30 bar (435 psi)

R

Process connection

Oval flange, mounting thread: 7/16"-20 UNF (IEC 61518)

L

Oval flange, mounting thread: M12 (PN 420) (DIN 19213)

M

Oval flange, mounting thread: 7/16"-20 UNF (IEC 61518) with lateral ventilation

N

Oval flange, mounting thread: M12 (PN 420) (DIN 19213) with lateral ventilation

P

Version for diaphragm seal with mounting thread 7/16"-20 UNF (IEC 61518)

V

Version for diaphragm seal with mounting thread M10 (DIN 19213)

W

Version for diaphragm seal (level and capillary) with mounting thread 7/16"-20 UNF (IEC 61518)

X

Wetted parts materials: Process connection, seal diaphragm

Stainless steel 316L/1.4404, stainless steel 316L/1.4404

0

Stainless steel 316L/1.4404, alloy C276/2.4819

1

Alloy C22/2.4602, alloy C276/2.4819

2

Tantalum/tantalum

4

Monel 00/2.4360, Monel 400/2.4360

6

Stainless steel 316L/1.4404, gold-plated

8

Non-wetted parts materials

Die-cast aluminum

1

Stainless steel precision casting CF3M/1.4409 similar to 316L

2

Enclosure

Dual chamber device

5

Type of protection

Without Ex

A

Intrinsic safety

B

Flameproof enclosure

C

Flameproof enclosure, intrinsic safety

D

Dust protection by enclosure Zone 21/22 (DIP), increased safety Zone 2

L

Dust protection by enclosure Zone 20/21/22 (DIP), increased safety Zone 2

M

Combination of options B, C and L (zone model)

S

Combination of options B, C and M (zone model, Class Division)

T

Electrical connections/cable entries

Thread for cable gland

- 2 x M20 x 1.5

- 2 x 1/2"-14 NPT

F

M

Local operation/display

Without display (cover closed)

0

With display (cover closed)

1

With display (cover with glass pane)

2

Pressure Measurement

Transmitters for applications with advanced requirements (Advanced)

SITRANS P320/P420

for differential pressure and flow

1

Selection and ordering data

Options	Order code	Options	Order code
Add "-Z" to article no. and specify order code.		Device options	
Cable glands included		PDF file with device settings	D10
Plastic	A00	Double layer coating (epoxy resin and polyurethane) 120 µm of enclosure and cover	D20
Metal	A01	FVMQ enclosure sealing	D21
Stainless steel	A02	IP66/IP68 degree of protection (not for M12 and Han device plugs)	D30
Stainless steel 316L/1.4404	A03	TAG label empty	D40
CMP, for XP devices	A10	Without labeling of the measuring range on the TAG label	D41
CAPRI ADE 4F, CuZn, cable inner diameter 7 ... 12 mm, cable outer diameter 10 ... 16 mm	A11	Stainless steel Ex plate 1.4404/316L	D42
CAPRI ADE 4F, stainless steel, cable inner diameter 7 ... 12 mm, cable outer diameter 10 ... 16 mm	A12	Increase of pressure stage from PN 420 to PN 500	D50
Han device plug mounted left		Overvoltage protection up to 6 kV (external)	D71
Han 7D device plug (plastic, straight)	A30	Adhesive labels on transport packaging (supplied by customer)	D90
Han 7D device plug (plastic, angled)	A31		
Han 7D device plug (metal, straight)	A32	General approval without Ex approval	
Han 7D device plug (metal, angled)	A33	Worldwide (CE, RCM) except EAC, FM, CSA, KCC	E00
Han 8D device plug (plastic, straight)	A34	Worldwide (CE, RCM, EAC, FM, CSA, KCC)	E01
Han 8D device plug (plastic, angled)	A35	CSA	E06
Han 8D device plug (metal, straight)	A36	EAC	E07
Han 8D device plug (metal, angled)	A37	FM	E08
Cable socket included		KCC	E09
Plastic, for Han 7D/8D device plugs	A40	UL	E10
Metal, for Han 7D/8D device plugs	A41	Explosion protection approvals	
M12 device plug mounted left		ATEX (Europe)	E20
Stainless steel, without cable socket	A62	CSA (USA and Canada)	E21
Stainless steel, with cable socket	A63	FM (USA and Canada)	E22
Cable entry/connector mounting		IECEX (Worldwide)	E23
2x sealing plugs M20 x 1.5, IP66/68 installed on both sides	A90	EACEx (GOST-R, -K, -B)	E24
2x sealing plugs ½-14 NPT, IP66/68 installed on both sides	A91	INMETRO (Brazil)	E25
Cable gland/connector mounted left	A97	KCs (Korea)	E26
Cable gland/connector mounted on right	A99	NEPSI (China)	E27
Nameplate labeling		PESO (India)	E28
German (bar)	B11	TIIS Hazardous (Japan)	E29
French (bar)	B12	UKR Sepro (Ukraine)	E30
Spanish (bar)	B13	ATEX (Europe) and IECEX (Worldwide)	E47
Italian (bar)	B14	CSA (Canada) and FM (USA)	E48
Chinese (bar)	B15	ATEX (Europe) and IECEX (Worldwide) + CSA (Canada) and FM (USA)	E49
Russian (bar)	B16	Marine approvals	
English (psi)	B20	DNV-GL (Det Norske Veritas/Germanischer Lloyd)	E50
Chinese (Pa)	B35	LR (Lloyds Register)	E51
Certificates		BV (Bureau Veritas)	E52
Quality test certificate, 5-point factory calibration (IEC 60770-2)	C11	ABS (American Bureau of Shipping)	E53
Acceptance certificate (EN 10204-3.1) - Material of pressurized and wetted parts	C12	KR (Korean Register of Shipping)	E56
Test report - NACE (MR 0103-2012 and MR 0175-2009)	C13	RINA (Registro Italiano Navale)	E57
Test report (EN 10204-2.2) - Wetted parts	C14	CCS (China Classification Society)	E58
Acceptance certificate (EN 10204-3.1) - PMI test of pressurized and wetted parts	C15	Country-specific approvals	
Certificates for functional safety		CRN approval Canada (Canadian Registration Number)	E60
Functional safety (IEC 61508) - SIL2/3	C20		

Pressure Measurement

Transmitters for applications with advanced requirements (Advanced)

SITRANS P320/P420

for differential pressure and flow

1

Options	Order code
Special approvals	
Oxygen application (with inert liquid, max. 100 bar (1 450 psi) at 60° C (140 °F))	E80
Dual seal	E81
WRC / WRAS (drinking water); only with pressure cap O-rings made of EPDM	E83
NSF61 (drinking water)	E84
ACS (drinking water)	E85
Mounting bracket	
Steel, galvanized	H01
Stainless steel 1.4301/304	H02
Stainless steel 1.4404/316L	H03
Process flanges; screw plug with vent valve	
Welded in on right	J08
Welded in on left	J09
Glued in on right	J10
Glued in on left	J11
Flange connections with flange EN 1092-1	
Form B1	
• DN 25 PN 40, stainless steel 1.4571/316Ti	J70
• DN 50 PN 40, stainless steel 1.4571/316Ti	J71
• DN 80 PN 40, stainless steel 1.4571/316Ti	J72
• DN 15 PN 40, stainless steel 1.4571/316Ti	J78
Form C	
• DN 25 PN 40, stainless steel 1.4571/316Ti	J73
• DN 50 PN 40, stainless steel 1.4571/316Ti	J74
• DN 80 PN 40, stainless steel 1.4571/316Ti	J75
Flange connection options	
Flange connection and temperature extension	J76
Flange connection with epoxy resin coating	J77
Process flanges; special materials	
Reserved for 7MF7: without process flanges, without screws, without gaskets	K00
Process flange material alloy C4/2.4610	K01
Process flange material Monel 400/2.4360	K02
Process connection material PVDF, on the side ½-14 NPT	K05
Process flanges/process connection material PVDF, flange on the side EN 1092-1 Form B1 DN 25 PN 40, MAWP 4 bar	K06
Process flanges/process connection material PVDF, flange on the side EN 1092-1 Form B1 DN 40 PN 40, MAWP 4 bar	K07
Process flanges; process connection option	
Process flange with process connection G½ welded on	K20
Process connection (oval flange) NAM (ASTAVA)	K21
Process flanges chambered with gaskets	
1x chambered, graphite	K40
1x chambered, PTFE	K41
2x chambered, PTFE	K42
Process flanges, gaskets (instead of standard gaskets FKM (FPM))	
O-ring, process flanges, PTFE	K50
O-ring, process flanges, FEP (with silicone core, approved for food)	K51
O-ring, process flanges, FFKM (FFPM)	K52
O-ring, process flanges, NBR	K53
O-ring, process flanges, EPDM	K54

Options	Order code
Process flange options	
Process flanges for vertical differential pressure lines (half process flange)	K81
Process flanges (+) - side front	K82
Process flange screws, process flange nuts, material Monel 400/2.4360	K83
Valve ¼-18 NPT, material same as process flanges	K84
Valve mounted on the side, measured medium: Gas	K85
Oval flange enclosed, gasket PTFE + mounting screws	K86
Pneumatic blocks	
With mounted pneumatic block (3-way) 7MF9411-5BA, PTFE sealing rings, chrome-plated steel screws and pressure test certified in test report (EN 10204-2.2)	U01
With mounted pneumatic block (3-way) 7MF9411-5BA, PTFE sealing rings, stainless steel screws and pressure test certified in test report (EN 10204-2.2)	U02
With mounted pneumatic block (5-way) 7MF9411-5CA, PTFE sealing rings, chrome-plated steel screws and pressure test certified in test report (EN 10204-2.2)	U03
With mounted pneumatic block (5-way) 7MF9411-5CA, PTFE sealing rings, stainless steel screws and pressure test certified in test report (EN 10204-2.2)	U04

Pressure Measurement

Transmitters for applications with advanced requirements (Advanced)
SITRANS P320/P420

for differential pressure and flow

1

Selection and ordering data

Customer-specific device settings	Order code
Add "-Z" to article no., specify order code and plain text or drop-down list selection.	
Measuring span Start of scale value (max. 5 characters), full scale value (max. 5 characters), unit [mbar, bar, kPa, MPa, psi, ...], example: -0.5 ... 10.5 psi Input field 1 and input field 2: max. 5 characters and numbers only; decimal places as dot (comma is automatically converted to dot). Drop-down list: Pa, MPa, kPa, hPa, bar, mbar, psi, g/cm ² , kg/cm ² , kgf/cm ² , inH ₂ O, inH ₂ O (4°C), ftH ₂ O, mmH ₂ O, mmH ₂ O (4°C), mH ₂ O (4°C), mmHg, inHg, atm, torr	Y01
Square-rooted characteristic [VSLN2, MSLN2], example: VSLN2 Drop-down list: VSLN2, MSLN2	Y02
TAG (on stainless steel plate and device parameters, max. 32 characters) Input field: Free text, max. 32 characters	Y15
Measuring point description (on stainless steel plate and device parameters, max. 32 characters) Input field: Free text, max. 32 characters	Y16
TAG short (device parameters, max. 8 characters) Input field: Free text, max. 8 characters	Y17
Local display [Pressure, Percent], reference [None, Absolute, Rela- tive], example: Pressure gauge Drop-down list: Percent, pressure unit, pressure unit abs., pressure unit gauge	Y21
Local display Scaling with standard units [m³/s, l/s, m, inch, ...], example 1 ... 5 m³/s Input field 1 and input field 2: max. 5 characters and numbers only; decimal places as dot (comma is automatically converted to dot). Drop-down list: m, cm, mm, in, ft, m ³ , l, hl, in ³ , ft ³ , yd ³ , gal (UK), bu, bbl, bbl (US), SCF, Nm ³ , NI, m ³ /sec, m ³ /h, m ³ /d, l/sec, l/min, l/h, Ml/d, ft ³ /sec, ft ³ /h, ft ³ /d, SCF/min, SCF/h, NI/h, Nm ³ /h, gal/sec, gal/min, gal/h, gal/d, Mgal/d, gal (UK)/sec, gal (UK)/min, gal (UK)/h, gal (UK)/d, bbl/sec, bbl/min, bbl/h, bbl/d, kg/sec, kg/min, kg/h, kg/d, g/sec, g/min, g/h, t/min, t/h, t/d, lb/sec, lb/min, lb/h, lb/d, ton/min, ton/h, ton/d, ton (UK)/h, ton (UK)/d.	Y22
Local display Scaling with user-specific units (max. 12 characters), example 1 ... 5 m Input field 1 and input field 2: max. 5 characters and numbers only; decimal places as dot (comma is automatically converted to dot). Input field 3: Free text, max. 8 characters	Y23
Saturation limits instead of 3.8 ... 20.5 mA, example: 3.8 ... 22.0 mA Drop-down list 1: 3.9, 4 Drop-down list 2: 20.8, 22	Y30
Fault current instead of 3.6 mA [22.5 mA, 22.8 mA] Drop-down list: 3.75; 21.75; 22.5; 22.6	Y31
Damping in seconds instead of 2 s (0.0 ... 100.0 s) Input field: max. 4 characters and numbers only; decimal places as dot (comma is automatically converted to dot); min. value = 0; max. value = 100.	Y32
ID number of special version Input field: max. 4 characters and only natural numbers from 0 ... 9999	Y99

Pressure Measurement

Transmitters for applications with advanced requirements (Advanced)

SITRANS P320/P420

for differential pressure and flow

1

Dimensional drawings

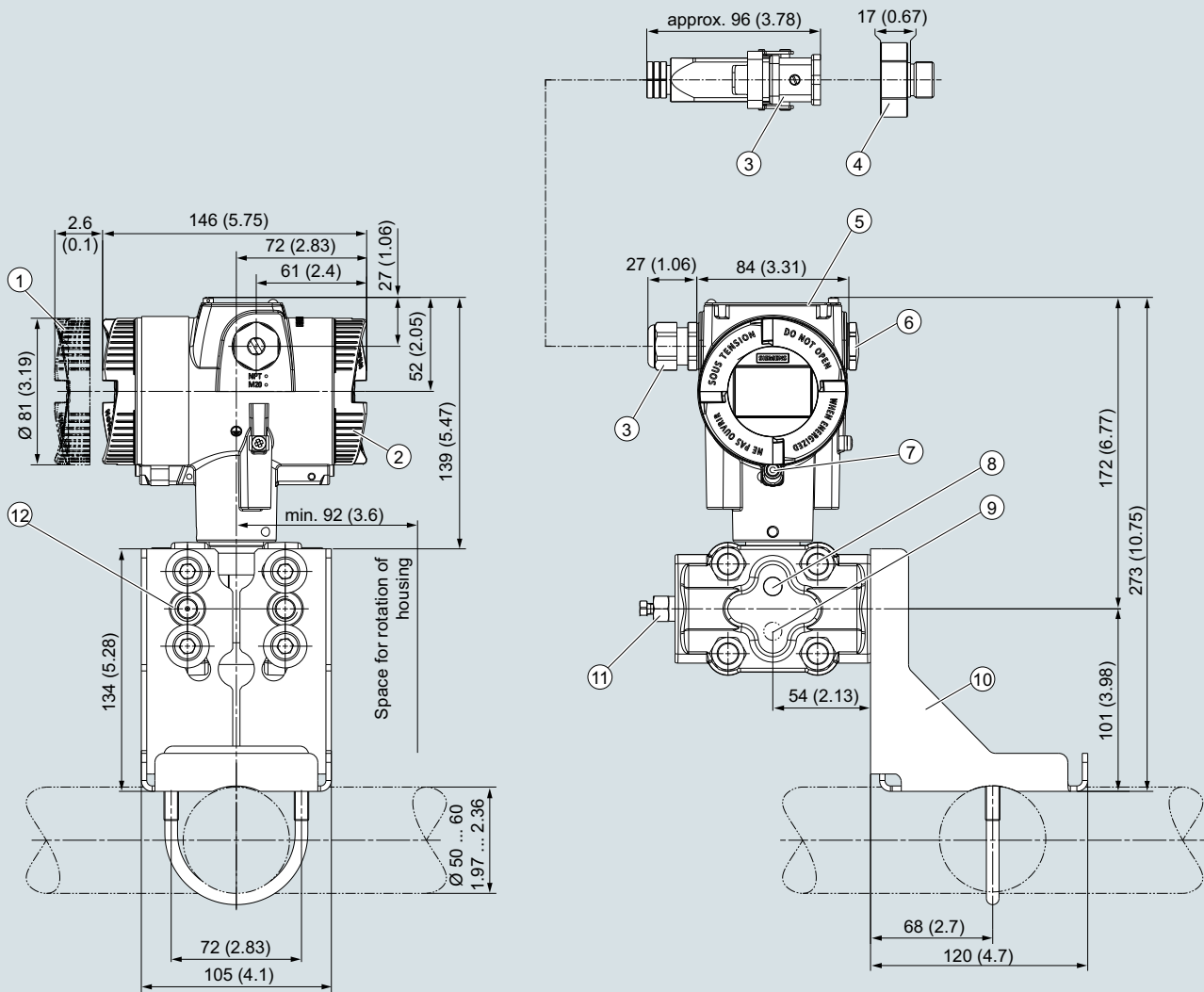

- | | |
|--|---|
| ① Electronic side, display
(longer overall length for cover with window) ¹⁾ | ⑥ Blanking plug |
| ② Terminal side | ⑦ Screw cover - safety bracket
(only for type of protection "Explosion-proof enclosure") |
| ③ Electrical connection:
screw gland M20 x 1,5 ³⁾ or screw gland ½-14 NPT or
Han 7D/Han 8D ^{2) 3)} device plug or M12 device plug ^{2) 3)} | ⑧ Lateral venting for liquid measurement (Standard) |
| ④ Harting adapter | ⑨ Lateral venting for gas measurement (suffix K85) |
| ⑤ Cover over buttons and nameplate with general information | ⑩ Mounting bracket (option) |
| | ⑪ Sealing screw with valve (option) |
| | ⑫ Process connection: ¼-18 NPT (IEC 61518) |

¹⁾ In addition, allow approx. 22 mm (0.87 inch) for the thread length when removing the covers

²⁾ Not with type of protection "Explosion-proof enclosure"

³⁾ Not with type of protection "FM + CSA" [is + XP]"

SITRANS P320/P420 pressure transmitter for differential pressure and flow, dimensions in mm (inch)

Pressure Measurement

Transmitters for applications with advanced requirements (Advanced)
SITRANS P320/P420

for differential pressure and flow

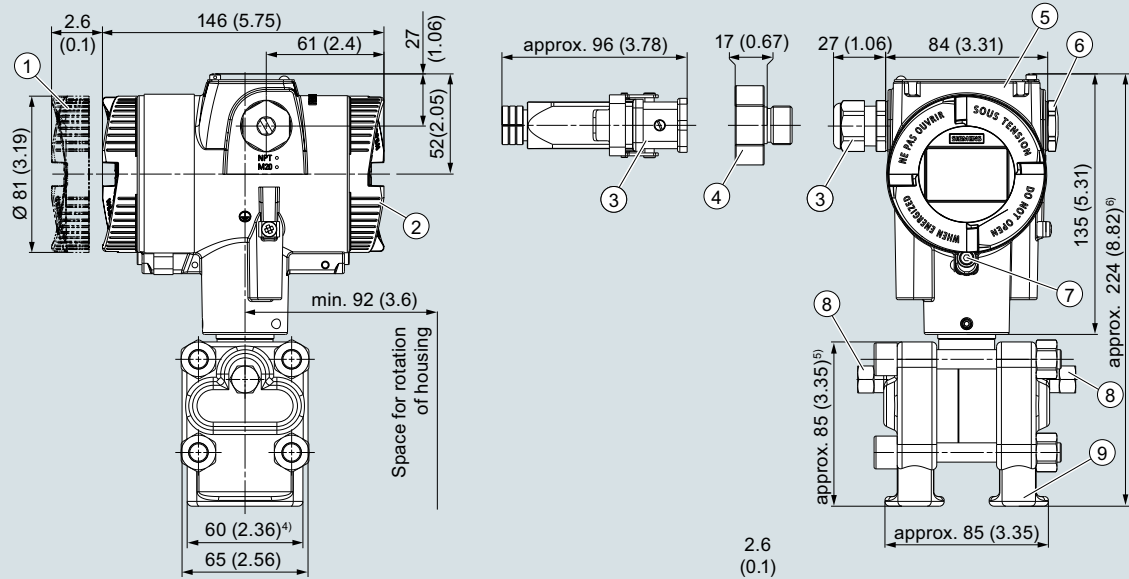

- ① Electronic side, display
(longer overall length for cover with window)¹⁾
- ② Terminal side
- ③ Electrical connection:
screw gland M20 x 1,5³⁾ or screw gland ½-14 NPT or
Han 7D/Han 8D²⁾ device plug or M12 device plug²⁾ 3
- ④ Harting adapter
- ⑤ Cover over buttons and nameplate
with general information
- ⑥ Blanking plug
- ⑦ Screw cover - safety bracket
(only for type of protection "Explosion-proof enclosure")
- ⑧ Sealing screw with valve (option)
- ⑨ Process connection: ¼-18 NPT (IEC 61518)

¹⁾ In addition, allow approx. 22 mm (0.87 inch) for the thread length when removing the covers

²⁾ Not with type of protection "Explosion-proof enclosure"

³⁾ Not with type of protection "FM + CSA" [is + XP]"

⁴⁾ 74 mm (2.9 inch) for PN ≥ 420 (MAWP ≥ 6092 psi)

⁵⁾ 91 mm (3.6 inch) for PN ≥ 420 (MAWP ≥ 6092 psi)

⁶⁾ 226 mm (8.9 inch) for PN ≥ 420 (MAWP ≥ 6092 psi)

SITRANS P320/P420 pressure transmitter for differential pressure and flow with process covers for vertical differential pressure lines (option "K81"), dimensions in mm (inch)

Pressure Measurement

Transmitters for applications with advanced requirements (Advanced)

SITRANS P320/P420

for level

1

Technical specifications

SITRANS P320 / SITRANS P420 for level

Input

Measured variable	Level		
Span (infinitely adjustable) and maximum operating pressure (pursuant to Pressure Equipment Directive 2014/68/EU)	Span	Max. permissible operating pressure MAWP (PS)	Maximum permissible test pressure
	25 ... 250 mbar	See "Mounting flange"	
	2.5 ... 25 kPa		
	10 ... 100.5 inH ₂ O		
	25 ... 600 mbar		
	2.5 ... 60 kPa		
	10 ... 241 inH ₂ O		
	53 ... 1600 mbar		
	5.3 ... 160 kPa		
	21 ... 643 inH ₂ O		
166 ... 5000 mbar			
16.6 ... 500 kPa			
2.41 ... 72.5 psi			
Measuring limits			
• Low measuring limit			
- Measuring cell with silicone oil filling	-100% of max. measuring range or 30 mbar a/3 kPa a/0.44 psi a depending on the mounting flange		
- Measuring cell with inert oil	-100% of max. measuring range or 30 mbar a/3 kPa a/0.44 psi a depending on the mounting flange		
- Measuring cell with FDA-compliant oil	-100% of max. measuring range or 100 mbar a/10 kPa a/1.45 psi a		
• Upper measuring limit	100% of max. span		
• Start of scale	Between the measuring limits (infinitely adjustable)		

Output

Output signal	HART
• Low saturation limit (infinitely adjustable)	4 ... 20 mA
• High saturation limit (infinitely adjustable)	3.55 mA, factory preset to 3.8 mA
• Ripple (without HART communication)	22.8 mA, factory-set to 20.5 mA or optionally 22.0 mA
Adjustable damping	$I_{pp} \leq 0.5\%$ of max. output current
• Current transmitter	0 ... 100 s, continuously adjustable over remote operation
• Failure signal	0 ... 100 s, in increments of 0.1 s, adjustable over display
Load	3.55 ... 22.8 mA
• Without HART communication	3.55 ... 22.8 mA
• With HART communication	Resistor R [Ω]
Characteristic curve	R = $(U_H - 10.5 \text{ V})/22.8 \text{ mA}$, U_H : Power supply in V
Physical bus	R = 230 ... 1100 Ω (HART communicator (handheld))
Polarity-independent	R = 230 ... 500 Ω (SIMATIC PDM)
	• Linearly increasing or linearly decreasing
	• Linear increase or decrease or according to the square root (only for differential pressure and flow)

Measuring accuracy

Reference conditions	<ul style="list-style-type: none"> • According to EN 60770-1 • Rising characteristic curve • Start of scale value 0 bar/kPa/psi • Seal diaphragm stainless steel • Measuring cell with silicone oil filling • Room temperature 25 °C (77 °F)
Conformity error at limit point setting, including hysteresis and repeatability	
Measuring span ratio r (spread, Turn-Down)	r = maximum measuring span/set measuring span or nominal measuring range
• Linear characteristic	
- 250 mbar/25 kPa/3.6 psi	r ≤ 5: ≤ 0.065% (SITRANS P320)
- 600 mbar/60 kPa/8.7 psi	≤ 0.004% (SITRANS P420)
- 1600 mbar/160 kPa/23.21 psi	
- 5 bar/500 kPa/72.5 psi	5 < r ≤ 10: ≤ (0.004 · r + 0.045)%

Pressure Measurement

Transmitters for applications with advanced requirements (Advanced)

SITRANS P320/P420

for level

SITRANS P320 / SITRANS P420 for level

Influence of ambient temperature ¹⁾ in % per 28 °C (50 °F)	
<ul style="list-style-type: none"> SITRANS P320 <ul style="list-style-type: none"> - 250 mbar/25 kPa/3.6 psi - 600 mbar/60 kPa/8.7 psi - 1600 mbar/160 kPa/23.21 psi - 5 bar/500 kPa/72.5 psi SITRANS P420 <ul style="list-style-type: none"> - 250 mbar/25 kPa/3.6 psi - 5 bar/500 kPa/72.5 psi - 600 mbar/60 kPa/8.7 psi - 1600 mbar/160 kPa/23.21 psi 	$\leq (0.025 \cdot r + 0.125)\%$ $\leq (0.025 \cdot r + 0.625)\%$ $\leq (0.125 \cdot r + 0.625)\%$
Effect of static pressure	
<ul style="list-style-type: none"> on the start of scale <ul style="list-style-type: none"> - 50 mbar/25 kPa/3.63 psi - 600 mbar/60 kPa/8.70 psi - 1600 mbar/160 kPa/23.21 psi - 5 bar/500 kPa/72.52 psi on the span 	$\leq (0.1 \cdot r)\%$ per nominal pressure $\leq (0.15 \cdot r)\%$ per nominal pressure $\leq (0.1 \cdot r)\%$ per nominal pressure
Long-term stability at ± 30 °C (± 54 °F)	
<ul style="list-style-type: none"> all measuring cells 	In 5 years $\leq (0.25 \cdot r)\%$ static pressure max. 70 bar/7 MPa/1015 psi
Step response time T_{63} (without electrical damping)	Approx. 0.2 s
Influence of mounting position	Depends on the fill fluid in the mounting flange
Effect of auxiliary power (in % per voltage change)	0.005% per 1 V
Rated conditions	
Temperature of medium	
Measuring cell with silicone oil filling	<ul style="list-style-type: none"> High-pressure side: See "Mounting flange" Low-pressure side: -40 ... +100 °C (-40 ... +212 °F)
Ambient conditions	
<ul style="list-style-type: none"> Ambient temperature/enclosure <ul style="list-style-type: none"> - Measuring cell with silicone oil filling - Display Storage temperature Climatic class in accordance with IEC 60721-3-4 Degree of protection <ul style="list-style-type: none"> - According to IEC 60529 - According to NEMA 250 Electromagnetic compatibility <ul style="list-style-type: none"> - Emitted interference and interference immunity 	Always consider the assignment of max. permissible operating temperature to max. permissible operating pressure of the respective flange connection. -40 ... +85 °C (-40 ... +185 °F) -20 ... +80 °C (-4 ... +176 °F) -50 ... +85 °C (-58 ... +185 °F) 4K4H IP66, IP68 Type 4X According to IEC 61326 and NAMUR NE 21
Vibration resistance	
<ul style="list-style-type: none"> Reference conditions General operating conditions <ul style="list-style-type: none"> - Oscillations (sine) IEC 60068-2-6 - Continuous shocks (half-sine) IEC 60068-2-27 - Noise (digitally controlled) IEC 60068-2-64 Rated conditions for marine applications <ul style="list-style-type: none"> - IEC 60068-2-6 - DNVGL-CG-0339, clause 6 - Lloyd's Register Test Specification Number 1, section 12. - Bureau Veritas Pt C, Ch 3, Sec 6, Table 1, No 7 	Specifications apply to devices without mounting bracket 10 ... 58 Hz, 0.3 mm (0.01 inch) 58 ... 500 Hz, 20 m/s ² (65.62 ft/s ²) 1 octave/min 5 cycles/axis 250 m/s ² (820 ft/s ²) 6 ms 2000 shocks/axis 10 ... 200 Hz; 1 (m/s ²)/Hz (3.28 (ft/s ²)/Hz) 200 ... 500 Hz; 0.3 (m/s ²)/Hz (0.98 (ft/s ²)/Hz) 4 hours/axle 2 ... 25 Hz, 1.6 mm (0.06 inch) 25 ... 100 Hz, 40 m/s ² (131.23 ft/s ²) 1 octave/min

Pressure Measurement

Transmitters for applications with advanced requirements (Advanced)

SITRANS P320/P420

for level

1

SITRANS P320 / SITRANS P420 for level**Design**

Weight

- According to EN (pressure transmitter with mounting flange, without tube)
- According to ASME (pressure transmitter with mounting flange, without tube)

Material

- Wetted parts materials

- High-pressure side

Seal diaphragm of mounting flange

Stainless steel, mat. no. 1.4404/316L, Monel 400, mat. no. 2.4360, Alloy B2, mat. no. 2.4617, Alloy C276, mat. no. 2.4819, Alloy C22, mat. no. 2.4602, tantalum, PTFE, PFA, ECTFE

Sealing surface

Smooth according to EN 1092-1, form B1 or ASME B16.5 RF 125 ... 250 AA for stainless steel 316L, EN 2092-1 form B2 or ASME B16.5 RFSF for the remaining materials

- Sealing material in the process flanges

For standard applications

Viton

For underpressure applications on the mounting flange

Copper

- Low-pressure side

Seal diaphragm

Stainless steel, mat. no. 1.4404/316L

Process flange locking screws

Stainless steel, mat. no. 1.4408

Screw plug

Stainless steel ISO 3506-1 A4-70

O-ring

FPM (Viton)

- Non-wetted parts materials

- Electronics housing

- Low-copper die-cast aluminum GD-AISI 12 or stainless steel precision casting, mat. no. 1.4409/ CF-3M
- Standard: Powder coating with polyurethane
Option: 2 coats: Coat 1: epoxy-based; coat 2: Polyurethane
- Stainless steel type plate (1.4404/316L)

Pressure flange screws

Stainless steel ISO 3506-1 A4-70

Measuring cell filling

Silicone oil

- Mounting flange fill fluid

Silicone oil or other material

Process connection

- High-pressure side
- Low-pressure side

Flange according to EN and ASME

1/4-18 NPT female thread and flat connection with M10 fastening screw thread in accordance with DIN 19213 (M12 for PN 420 (MWP 6092 psi)) or 7/16-20 UNF in accordance with EN 61518

Electrical connection

Screw terminals

Cable entry via the following screwed glands:

- M20 x 1.5
- 1/2-14 NPT
- Han 7D/Han 8D device plug²⁾
- M12 device plug

Displays and controls

Keys

4 keys for operation directly on the device

Display

- With or without integrated display (optional)
- Cover with inspection window (optional)

Auxiliary power U_H

Terminal voltage on pressure transmitter

10.5 ... 45 V DC
10.5 ... 30 V DC in intrinsically safe mode

Ripple

 $U_{SS} \leq 0.2 \text{ V}$ (47 ... 125 Hz)

Noise

 $U_{\text{eff}} \leq 1.2 \text{ mV}$ (0.5 ... 10 kHz)

Auxiliary power

-

Separate supply voltage

-

Pressure Measurement

Transmitters for applications with advanced requirements (Advanced)

SITRANS P320/P420

for level

SITRANS P320 / SITRANS P420 for level

Certificates and approvals

Classification according to pressure equipment directive (PED 2014/68/EU)

Drinking water

- WRAS (England)
- ACS (France)
- DVGW (Germany)
- NSF (USA)

CRN (Canada)

Explosion protection acc. to NEPSI (China)

Explosion protection acc. to INMETRO (Brazil)

BAM (Germany), oxygen expenditures

Explosion protection

- Intrinsic safety "i"

- Marking

- Permissible ambient temperature

- Permissible temperature of measuring medium

- Connection

- Effective internal inductance/capacitance

- Flameproof enclosure "d"

- Marking

- Permissible ambient temperature

- Permissible temperature of measuring medium

- Connection

- Dust explosion protection for Zone 20, 21, 22

- Marking

- Permissible ambient temperature

- Permissible temperature of measuring medium

- Max. surface temperature

- Connection

- Dust explosion protection for Zone 20, 21, 22

- Marking

- Permissible ambient temperature

- Permissible temperature of measuring medium

- Connection

- Effective internal inductance/capacitance

- Type of protection for Zone 2

- Marking

- Permissible ambient temperature "ec"

- Permissible ambient temperature "ic"

- Permissible temperature of measuring medium

- "ec" connection

- "ic" connection

For gases of fluid group 1 and liquids of fluid group 1; complies with requirements of article 4, paragraph 3 (sound engineering practice)

Available soon

Available soon

Available soon

Available soon

Available soon

Available soon

Available soon

Available soon

II 1/2 G Ex ia/ib IIC T4/T6 Ga/Gb

-40 ... +80 °C (-40 ... +176 °F) temperature class T4

-40 ... +70 °C (-40 ... +158 °F) temperature class T6

-40 ... +100 °C (-40 ... +212 °F) temperature class T4

-40 ... +70 °C (-40 ... +158 °F) temperature class T6

To certified intrinsically safe circuits with peak values:

$U_i = 30 \text{ V}$, $I_i = 101 \text{ mA}$, $P_i = 760 \text{ mW}$

$U_i = 29 \text{ V}$, $I_i = 110 \text{ mA}$, $P_i = 800 \text{ mW}$

$L_i = 0.24 \text{ } \mu\text{H/C}_i = 3.29 \text{ nF}$

Ex II 1/2 G Ex ia/db IIC T4/T6 Ga/Gb

-40 ... +80 °C (-40 ... +176 °F) temperature class T4

-40 ... +70 °C (-40 ... +158 °F) temperature class T6

-40 ... +100 °C (-40 ... +212 °F) temperature class T4

-40 ... +70 °C (-40 ... +158 °F) temperature class T6

To a circuit with the operating values:

$U_n = 10.5 \text{ to } 45 \text{ V}$, $4 \text{ ... } 20 \text{ mA}$

Ex II 1D Ex tb IIIC T120 °C Da

Ex II 2D Ex tb IIIC T120 °C Db

Ex II 3D Ex tc IIIC T120 °C Dc

-40 ... +80 °C (-40 ... +176 °F)

-40 ... +100 °C (-40 ... +212 °F)

120 °C (248 °F)

To a circuit with the operating values:

$U_n = 10.5 \text{ to } 45 \text{ V}$, $4 \text{ ... } 20 \text{ mA}$

Ex II 1D Ex ia IIIC T120 °C Da

Ex II 2D Ex ib IIIC T120 °C Db

Ex II 3D Ex ic IIIC T120 °C Dc

-40 ... +80 °C (-40 ... +176 °F)

-40 ... +100 °C (-40 ... +212 °F)

To certified intrinsically safe circuits with the peak values:

$U_i = 30 \text{ V}$, $I_i = 101 \text{ mA}$, $P_i = 760 \text{ mW}$

$U_i = 29 \text{ V}$, $I_i = 110 \text{ mA}$, $P_i = 800 \text{ mW}$

$L_i = 0.24 \text{ } \mu\text{H/C}_i = 3.29 \text{ nF}$

Ex II 3G Ex ec IIC T4/T6 Gc

Ex II 3G Ex ic IIC T4/T6 Gc

-40 ... +80 °C (-40 ... +176 °F) temperature class T4

-40 ... +40 °C (-40 ... +104 °F) temperature class T6

-40 ... +80 °C (-40 ... +176 °F) temperature class T4

-40 ... +80 °C (-40 ... +176 °F) temperature class T6

-40 ... +100 °C (-40 ... +212 °F) temperature class T4

-40 ... +70 °C (-40 ... +158 °F) temperature class T6

To a circuit with the operating values:

$U_n = 10.5 \text{ to } 30 \text{ V}$, $4 \text{ ... } 20 \text{ mA}$

To certified intrinsically safe circuits with the peak values:

$U_i = 30 \text{ V}$, $I_i = 101 \text{ mA}$, $P_i = 760 \text{ mW}$

$U_i = 29 \text{ V}$, $I_i = 110 \text{ mA}$, $P_i = 800 \text{ mW}$

Effective internal inductance/capacitance:

$L_i = 0.24 \text{ } \mu\text{H/C}_i = 3.29 \text{ nF}$

Pressure Measurement

Transmitters for applications with advanced requirements (Advanced)

SITRANS P320/P420

for level

1

SITRANS P320 / SITRANS P420 for level

<ul style="list-style-type: none"> Explosion protection acc. to FM <ul style="list-style-type: none"> - Marking (XP/DIP) or IS; NI; S 	Available soon CL I, DIV 1, GP ABCD T4 ... T6; CL II, DIV 1, GP EFG; CL III; Ex ia IIC T4 ... T6: CL I, DIV 2, GP ABCD T4 ... T6; CL II, DIV 2, GP FG; CL III
<ul style="list-style-type: none"> Explosion protection according to CSA <ul style="list-style-type: none"> - Marking (XP/DIP) or (IS) 	Available soon CL I, DIV 1, GP ABCD T4 ... T6; CL II, DIV 1, GP EFG; CL III; Ex ia IIC T4 ... T6: CL I, DIV 2, GP ABCD T4 ... T6; CL II, DIV 2, GP FG; CL III

1) Specification only applies to the basic unit. The remote seal error must be considered additively.

2) Han 8D is identical to Han 8U.

HART communication

HART	230 ... 1100 Ω
Protocol	HART 7
Software for computer	SIMATIC PDM

Mounting flange

Nominal diameter	Nominal pressure
<ul style="list-style-type: none"> Acc. to EN 1092-1 <ul style="list-style-type: none"> - DN 80 - DN100 According to ASME B16.5 <ul style="list-style-type: none"> - 3 inch - 4 inch 	PN 40 PN 16, PN 40 Class 150, class 300 Class 150, class 300

Pressure Measurement

Transmitters for applications with advanced requirements (Advanced)
SITRANS P320/P420

for level

1

Selection and ordering data

	Article No.
Pressure transmitters for level	
SITRANS P320	7MF036
SITRANS P420	7MF046
Click on the Article no. for the online configuration in the PIA Life Cycle Portal.	
Communication	
HART, 4 ... 20 mA	0
Measuring cell filling	
Silicone oil	1
Inert liquid	3
Neobee oil	4
Maximum measuring span	
250 mbar (100.5 inH ₂ O)	G
600 mbar (241 inH ₂ O)	H
1 600 mbar (643 inH ₂ O)	M
5000 mbar (72.5 psi)	P
Process connection	
Version for diaphragm seal with mounting thread 7/16"-20 UNF (IEC 61518)	V
Wetted parts materials: Process connection, seal diaphragm	
Stainless steel 316L/1.4404, stainless steel 316L/1.4404	0
Non-wetted parts materials	
Die-cast aluminum	1
Stainless steel precision casting CF3M/1.4409 similar to 316L	2
Enclosure	
Dual chamber device	5
Type of protection	
Without Ex	A
Intrinsic safety	B
Flameproof enclosure	C
Flameproof enclosure, intrinsic safety	D
Dust protection by enclosure Zone 21/22 (DIP), increased safety Zone 2	L
Dust protection by enclosure Zone 20/21/22 (DIP), increased safety Zone 2	M
Combination of options B, C and L (zone model)	S
Combination of options B, C and M (zone model, Class Division)	T
Electrical connections/cable entries	
Thread for cable gland	
• 2 x M20 x 1.5	F
• 2 x 1/2-14 NPT	M
Local operation/display	
Without display (cover closed)	0
With display (cover closed)	1
With display (cover with glass pane)	2

Selection and ordering data

<i>Options</i>	Order code	<i>Options</i>	Order code
Add "-Z" to article no. and specify order code.		Device options	
Cable glands included		PDF file with device settings	D10
Plastic	A00	Double layer coating (epoxy resin and polyurethane) 120 µm of enclosure and cover	D20
Metal	A01	FVMQ enclosure sealing	D21
Stainless steel	A02	IP66/IP68 degree of protection (not for M12 and Han device plugs)	D30
Stainless steel 316L/1.4404	A03	TAG label empty	D40
CMP, for XP devices	A10	Without labeling of the measuring range on the TAG label	D41
CAPRI ADE 4F, CuZn, cable inner diameter 7 ... 12 mm, cable outer diameter 10 ... 16 mm	A11	Stainless steel Ex plate 1.4404/316L	D42
CAPRI ADE 4F, stainless steel, cable inner diameter 7 ... 12 mm, cable outer diameter 10 ... 16 mm	A12	Increase of pressure stage from PN 420 to PN 500	D50
Han device plug mounted left		Overvoltage protection up to 6 kV (external)	D71
Han 7D device plug (plastic, straight)	A30	Adhesive labels on transport packaging (supplied by customer)	D90
Han 7D device plug (plastic, angled)	A31		
Han 7D device plug (metal, straight)	A32	General approval without Ex approval	
Han 7D device plug (metal, angled)	A33	Worldwide (CE, RCM) except EAC, FM, CSA, KCC	E00
Han 8D device plug (plastic, straight)	A34	Worldwide (CE, RCM, EAC, FM, CSA, KCC)	E01
Han 8D device plug (plastic, angled)	A35	CSA	E06
Han 8D device plug (metal, straight)	A36	EAC	E07
Han 8D device plug (metal, angled)	A37	FM	E08
Cable socket included		KCC	E09
Plastic, for Han 7D/8D device plugs	A40	UL	E10
Metal, for Han 7D/8D device plugs	A41	Explosion protection approvals	
M12 device plug mounted left		ATEX (Europe)	E20
Stainless steel, without cable socket	A62	CSA (USA and Canada)	E21
Stainless steel, with cable socket	A63	FM (USA and Canada)	E22
Cable entry/connector mounting		IECEX (Worldwide)	E23
2x sealing plugs M20 x 1.5, IP66/68 installed on both sides	A90	EACEx (GOST-R, -K, -B)	E24
2x sealing plugs ½-14 NPT, IP66/68 installed on both sides	A91	INMETRO (Brazil)	E25
Cable gland/connector mounted left	A97	KCs (Korea)	E26
Cable gland/connector mounted on right	A99	NEPSI (China)	E27
Nameplate labeling		PESO (India)	E28
German (bar)	B11	TIIS Hazardous (Japan)	E29
French (bar)	B12	UKR Sepro (Ukraine)	E30
Spanish (bar)	B13	ATEX (Europe) and IECEX (Worldwide)	E47
Italian (bar)	B14	CSA (Canada) and FM (USA)	E48
Chinese (bar)	B15	ATEX (Europe) and IECEX (Worldwide) + CSA (Canada) and FM (USA)	E49
Russian (bar)	B16	Marine approvals	
English (psi)	B20	DNV-GL (Det Norske Veritas/Germanischer Lloyd)	E50
Chinese (Pa)	B35	LR (Lloyds Register)	E51
Certificates		BV (Bureau Veritas)	E52
Quality test certificate, 5-point factory calibration (IEC 60770-2)	C11	ABS (American Bureau of Shipping)	E53
Acceptance certificate (EN 10204-3.1) - Material of pressurized and wetted parts	C12	KR (Korean Register of Shipping)	E56
Test report - NACE (MR 0103-2012 and MR 0175-2009)	C13	RINA (Registro Italiano Navale)	E57
Test report (EN 10204-2.2) - Wetted parts	C14	CCS (China Classification Society)	E58
Acceptance certificate (EN 10204-3.1) - PMI test of pressurized and wetted parts	C15	Country-specific approvals	
Certificates for functional safety		CRN approval Canada (Canadian Registration Number)	E60
Functional safety (IEC 61508) - SIL2/3	C20		

Pressure Measurement

Transmitters for applications with advanced requirements (Advanced)

SITRANS P320/P420

for level

1

Options	Order code	Selection and ordering data	Order code
Special approvals		Customer-specific device settings	
Oxygen application (with inert liquid, max. 100 bar (1 450 psi) at 60° C (140 °F))	E80	Add "-Z" to article no., specify order code and plain text or drop-down list selection.	
Dual seal	E81		
WRC / WRAS (drinking water); only with pressure cap O-rings made of EPDM	E83	Measuring span	Y01
NSF61 (drinking water)	E84	Start of scale value (max. 5 characters), full scale value (max. 5 characters), unit [mbar, bar, kPa, MPa, psi, ...], example: -0.5 ... 10.5 psi	
ACS (drinking water)	E85	Input field 1 and input field 2: max. 5 characters and numbers only; decimal places as dot (comma is automatically converted to dot). Drop-down list: Pa, MPa, kPa, hPa, bar, mbar, psi, g/cm ² , kg/cm ² , kgf/cm ² , inH ₂ O, inH ₂ O (4°C), ftH ₂ O, mmH ₂ O, mmH ₂ O (4°C), mH ₂ O (4°C), mmHg, inHg, atm, torr	
		TAG (on stainless steel plate and device parameters, max. 32 characters)	Y15
		Input field: Free text, max. 32 characters	
		Measuring point description (on stainless steel plate and device parameters, max. 32 characters)	Y16
		Input field: Free text, max. 32 characters	
		TAG short (device parameters, max. 8 characters)	Y17
		Input field: Free text, max. 8 characters	
		Local display [Pressure, Percent], reference [None, Absolute, Relative], example: Pressure gauge	Y21
		Drop-down list: Percent, pressure unit, pressure unit abs., pressure unit gauge	
		Local display Scaling with standard units [m³/s, l/s, m, inch, ...], example 1 ... 5 m	Y22
		Input field 1 and input field 2: max. 5 characters and numbers only; decimal places as dot (comma is automatically converted to dot). Drop-down list: m, cm, mm, in, ft, m ³ , l, hl, in ³ , ft ³ , yd ³ , gal, gal (UK), bu, bbl, bbl (US), SCF, Nm ³ , NI.	
		Local display Scaling with user-specific units (max. 12 characters), example 1 ... 5 m	Y23
		Input field 1 and input field 2: max. 5 characters and numbers only; decimal places as dot (comma is automatically converted to dot). Input field 3: Free text, max. 8 characters	
		Saturation limits instead of 3.8 ... 20.5 mA, example: 3.8 ... 22.0 mA	Y30
		Drop-down list 1: 3.9, 4 Drop-down list 2: 20.8, 22	
		Fault current instead of 3.6 mA [22.5 mA, 22.8 mA]	Y31
		Drop-down list: 3.75; 21.75; 22.5; 22.6	
		Damping in seconds instead of 2 s (0.0 ... 100.0 s)	Y32
		Input field: max. 4 characters and numbers only; decimal places as dot (comma is automatically converted to dot); min. value = 0; max. value = 100.	
		ID number of special version	Y99
		Input field: max. 4 characters and only natural numbers from 0 ... 9999	

Pressure Measurement

Transmitters for applications with advanced requirements (Advanced)

SITRANS P320/P420

for level

1

Selection and Ordering data		Article No.	Order code	Selection and Ordering data		Article No.	Order code
Diaphragm seal		7MF0814 -	03 - 0	Diaphragm seal		7MF0814 -	03 - 0
Flange type design, direct connected to a SITRANS P transmitter for level 7MF03../7MF04.. (order separately) Scope of delivery: 1 off				Flange type design, direct connected to a SITRANS P transmitter for level 7MF03../7MF04.. (order separately) Scope of delivery: 1 off			
Click on the Article No. for the online configuration in the PIA Life Cycle Portal.				Filling liquid			
Connecting standard EN 1092-1				Silicone oil M5		A	
Nominal diameter	Nominal pressure			Silicone oil M50	B		
DN 40	PN 10/16/25/40	0DD		High-temperature oil	C		
	PN 63/100	0DF		Halocarbon oil	D		
	PN 160	0DG		Food-grade oil (FDA listed)	E		
DN 50	PN 10/16/25/40	0ED		Other version, add Order code and plain text:	Z	P 1 Y	
	PN 63/100	0EE		Filling liquid: ...			
	PN 160	0EF		Wetted parts materials			
DN 80	PN 10/16/25/40	0GD		Stainless steel 316L	A		
	PN 100	0GF		• Without coating	D		
DN 100	PN 10/16	0HB		• With PFA coating	E 0		
	PN 25/40	0HD		• With PTFE coating	F		
DN 125	PN 16	0JB		• With ECTFFE coating	G		
	PN 40	0JD		Monel 400, 2.4360	J		
Connecting standard ASME B16.5				Hastelloy C276, 2.4819	K		
Nominal diameter	Nominal pressure			Tantalum	L 0		
1½ inch	class 150	1LA		Titanium, 3.7035	M 0		
	class 300	1LB		Nickel 201	Q		
	class 400/600	1LD		Diaphragm Duplex, 1.4462	R		
	class 900/1500	1LF		Diaphragm plus flange Duplex, 1.4462	S 0		
2 inch	class 150	1MA		Stainless steel 316L with gold coating	U 0		
	class 300	1MB		Hastelloy C4, 2.4610	V 0		
	class 400/600	1MD		Hastelloy C22, 2.4602	Z 8	Q 1 Y	
	class 900/1500	1MF		Other version			
3 inch	class 150	1PA		Add Order code and plain text			
	class 300	1PB		Extension length			
	class 600	1PD		• without	0		
	class 1500	1PF		• 50 mm (2")	1		
4 inch	class 150	1QA		• 100 mm (4")	2		
	class 300	1QB		• 150 mm (6")	3		
	class 400	1QD		• 200 mm (8")	4		
	class 1500	1QF		• 250 mm (10")	5		
5 inch	class 150	1RA		Other version	Z 8	Q 1 Y	
	class 300	1RB		Add Order code and plain text			
	class 400	1RC		Extension length			
Connecting standard J.I.S.				• without	0		
Nominal diameter	Nominal pressure			• 50 mm (2")	1		
DN 50	10K	2ES		• 100 mm (4")	2		
	20k	2ET		• 150 mm (6")	3		
	50K	2EU		• 200 mm (8")	4		
DN 80	10K	2GS		• 250 mm (10")	5		
	20k	2GT		Other version	Z 8	Q 1 Y	
	50K	2GU		Add Order code and plain text			
DN 100	10K	2HS		Extension length			
	20k	2HT		• without	0		
	50K	2HU		• 50 mm (2")	1		
Other version		9AA	H 1 Y	• 100 mm (4")	2		
Add Order code and plain text				• 150 mm (6")	3		
				• 200 mm (8")	4		
				• 250 mm (10")	5		
				Other version	Z 8	Q 1 Y	
				Add Order code and plain text			

Pressure Measurement

Transmitters for applications with advanced requirements (Advanced)

SITRANS P320/P420

for level

1

Selection and Ordering data

Article No.

Order code

Diaphragm seal

Flange type design, direct connected to a SITRANS P transmitter for level
7MF03../7MF04.. (order separately)
Scope of delivery: 1 off

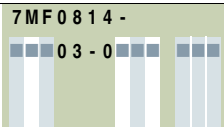

Customer-specific extension length

Wetted parts stainless steel without coating

Range	Standard length	
20 ... 50 mm (0.79 ... 1.97")	50 mm (1.97")	A 1
51 ... 100 mm (2.01 ... 3.94")	100 mm (3.94")	A 2
101 ... 150 mm (3.98 ... 5.91")	150 mm (5.91")	A 3
151 ... 200 mm (5.94 ... 7.87")	200 mm (7.87")	A 4
201 ... 250 mm (7.91 ... 9.84")	250 mm (9.84")	A 5

Wetted parts stainless steel with ECTFE coating

Range	Standard length	
20 ... 50 mm (0.79 ... 1.97")	50 mm (1.97")	F 1
51 ... 100 mm (2.01 ... 3.94")	100 mm (3.94")	F 2
101 ... 150 mm (3.98 ... 5.91")	150 mm (5.91")	F 3
151 ... 200 mm (5.94 ... 7.87")	200 mm (7.87")	F 4
201 ... 250 mm (7.91 ... 9.84")	250 mm (9.84")	F 5

Wetted parts stainless steel with PFA coating

Range	Standard length	
20 ... 50 mm (0.79 ... 1.97")	50 mm (1.97")	D 1
51 ... 100 mm (2.01 ... 3.94")	100 mm (3.94")	D 2
101 ... 150 mm (3.98 ... 5.91")	150 mm (5.91")	D 3
151 ... 200 mm (5.94 ... 7.87")	200 mm (7.87")	D 4
201 ... 250 mm (7.91 ... 9.84")	250 mm (9.84")	D 5

• Wetted parts Monel 400

Range	Standard length	
20 ... 50 mm (0.79 ... 1.97")	50 mm (1.97")	G 1
51 ... 100 mm (2.01 ... 3.94")	100 mm (3.94")	G 2
101 ... 150 mm (3.98 ... 5.91")	150 mm (5.91")	G 3
151 ... 200 mm (5.94 ... 7.87")	200 mm (7.87")	G 4

• Wetted parts Hastelloy C276

Range	Standard length	
20 ... 50 mm (0.79 ... 1.97")	50 mm (1.97")	J 1
51 ... 100 mm (2.01 ... 3.94")	100 mm (3.94")	J 2
101 ... 150 mm (3.98 ... 5.91")	150 mm (5.91")	J 3
151 ... 200 mm (5.94 ... 7.87")	200 mm (7.87")	J 4

Selection and Ordering data

Article No.

Order code

Diaphragm seal

Flange type design, direct connected to a SITRANS P transmitter for level
7MF03../7MF04.. (order separately)
Scope of delivery: 1 off

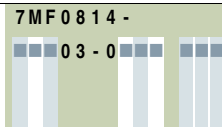

• Wetted parts Tantalum

Range	Standard length	
20 ... 50 mm (0.79 ... 1.97")	50 mm (1.97")	K 1
51 ... 100 mm (2.01 ... 3.94")	100 mm (3.94")	K 2
101 ... 150 mm (3.98 ... 5.91")	150 mm (5.91")	K 3
151 ... 200 mm (5.94 ... 7.87")	200 mm (7.87")	K 4

Pressure Measurement

Transmitters for applications with advanced requirements (Advanced)

SITRANS P320/P420

for level

1

Selection and Ordering data	Order code	Selection and Ordering data	Order code
Further designs		Further designs	
Add "-Z" to Article No. and specify Order code.		Add "-Z" to Article No. and specify Order code.	
Factory certificates		Sealing surface	
Quality inspection certificate (Five-step factory calibration) to IEC 60770-2	C11	Operating Temperature; Lower range value ... °C (°F), upper range value ... °C (°F)	Y10
Inspection certificate to EN 10204-3.1 - material of body and wetted parts	C12	Static pressure: ... bar (psi)	Y11
Manufacturer's declaration acc. to NACE (MR 0103-2012 and MR 0175-2009) (only together with seal diaphragm made of Hastelloy and stainless steel)	C13	Customer specific extension length (enter required length in plain text)	Y44
Inspection certificate (EN 10204-3.1) - PMI test of pressure containing and wetted parts	C15		
Certificate of FDA-approved fill oil (to EN10204-2.2)	C17		
Functional safety (SIL2/3) Devices suitable for use according to IEC 61508 and IEC 61511 (Includes SIL conformity declaration)	C20		
Accessories			
Spark arrester (for differential pressure and level transmitter)	D62		
Low-temperature version (for Silicon Oil M50 only)	D67		
Negative pressure services			
Certification acc. to NACE MR-0103	D83		
Includes acceptance test certificate 3.1 acc. to EN 10204 (only for wetted parts made of stainless steel 1.4404/316L and Hastelloy C276)	D88		
General product approvals without explosion proof approvals			
Oil-and grease-free cleaned version (for O ₂ -appl. including certificate EN10204-2.2 (only with fill fluid Halocarbon oil max. temperature 60 °C and max. pressure 50 bar)	E80		
Oil-and grease-free cleaned version (not for O ₂ -appl. including certificate EN10204-2.2 (only with fill fluid Halocarbon oil)	E87		
Sealing surface			
Sealing surface smooth, form B2/EN1092-1 resp. RFSF/ANSI B16.5 (wetted parts 316L only)	M50		
Sealing surface groove to EN1092-1, form D (instead of sealing surface B1, wetted parts 316L only)	M54		
Sealing surface RJF (groove) to ASME B16.5 (instead of sealing surface RF 125...250AA, wetted parts 316L only)	M64		
Sealing surface with tongue to EN1092-1, form C (wetted parts 316L only)			
• DN 40	M71		
• DN 50	M72		
• DN 80	M73		
• DN 100	M74		
• DN 125	M75		
Sealing surface with spigot to EN1092-1, form E (wetted parts 316L only)			
• DN 40	M77		
• DN 50	M78		
• DN 80	M79		
• DN 100	M80		
• DN 125	M81		
Sealing surface with recess to EN1092-1, form F (wetted parts 316L only)			
• DN 50	M84		
• DN 80	M85		
• DN 100	M86		
• DN 125	M87		

Pressure Measurement

Transmitters for applications with advanced requirements (Advanced)

SITRANS P320/P420

for level

Dimensional drawings

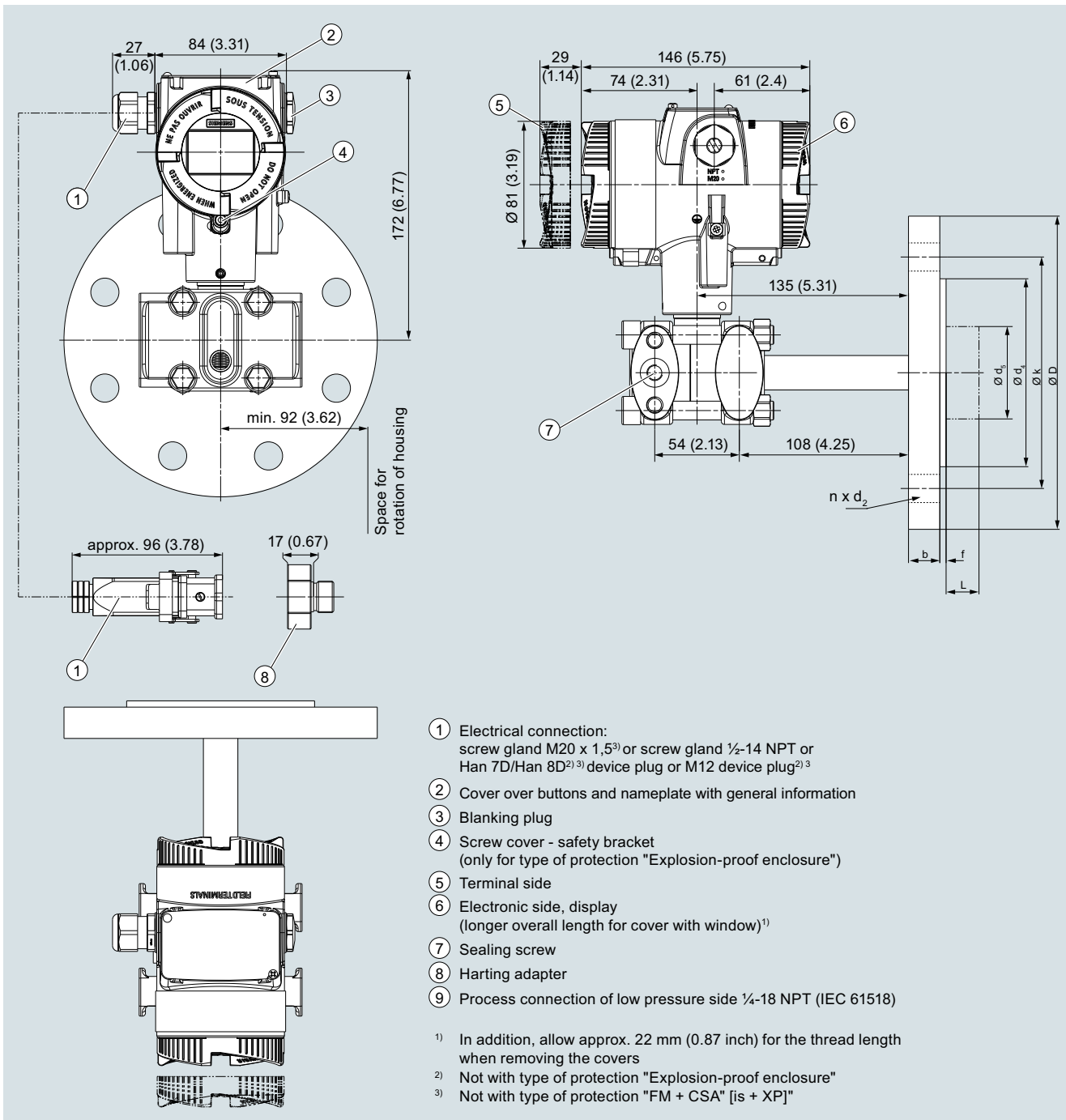

SITRANS P320/P420 pressure transmitter for level, including mounting flange, dimensions in mm (inch)

Pressure Measurement

Transmitters for applications with advanced requirements (Advanced)

SITRANS P320/P420

for level

1

Connection to EN 1092-1

Nominal diameter	Nominal pressure	b	D	d ₂	d ₄	d ₅	d _M with tube	d _M without tube	f	k	n	L
		mm	mm	mm	mm	mm	mm	mm	mm	mm	mm	mm
DN 40	PN 10/16/25/40	16	150	18	88	38	30	42	2	110	4	0, 50, 100, 150 or 200
	PN 63/100	24	170	22	88	38	30	42	2	125	4	
	PN 160	26	170	22	88	38	30	42	2	125	4	
DN 50	PN 10/16/25/40	18	165	18	102	48.3	40	51	2	125	4	
	PN 63/100	26	195	26	102	48.3	40	51	2	145	4	
	PN 160	28	195	26	102	48.3	40	51	2	145	4	
DN 80	PN 10/16/25/40	22	200	18	138	76	65	85	2	160	8	
	PN 100	30	230	26	138	76	65	85	2	180	8	
DN 100	PN 10/16	18	220	18	158	94	85	85	2	180	8	
	PN 25/40	22	235	22	162	94	85	85	2	190	8	
DN 125	PN 16	20	250	18	188	127	85	116	2	210	8	
	PN 40	24	270	26	188	127	85	116	2	220	8	

Connection according to ASME B16.5

Nominal diameter	Nominal pressure	b	D	d ₂	d ₄	d ₅	d _M with tube	d _M without tube	f	k	n	L
		lb/sq.in. inch (mm)	inch (mm)	inch (mm)	inch (mm)	inch (mm)	inch (mm)	inch (mm)	inch (mm)	inch (mm)	inch (mm)	inch (mm)
1½ inch	150	0.63 (15.9)	4.92 (125)	0.63 (15.9)	2.87 (73)	1.5 (38)	1.18 (30)	1.42 (36)	0.08 (2)	3.87 (98.4)	4	0, 2, 3.94, 5.94 or 7.87 (0, 50, 100, 150 or 200)
	300	0.75 (19.1)	6.10 (155)	0.87 (22.2)	2.87 (73)	1.5 (38)	1.18 (30)	1.42 (36)	0.08 (2)	4.5 (114.3)	4	
	400/600	0.88 (22.3)	6.10 (155)	0.87 (22.2)	2.87 (73)	1.5 (38)	1.18 (30)	1.42 (36)	0.28 (7)	4.5 (114.3)	4	
	900/1500	1.25 (31.8)	7.09 (180)	1.13 (28.6)	2.87 (73)	1.5 (38)	1.18 (30)	1.42 (36)	0.28 (7)	4.87 (123.8)	4	
2 inch	150	0.69 (17.5)	5.91 (150)	0.75 (19.1)	3.63 (92.1)	1.9 (48.3)	1.57 (40)	2.01 (51)	0.08 (2)	4.75 (120.7)	4	
	300	0.81 (20.7)	6.5 (165)	0.75 (19.1)	3.63 (92.1)	1.9 (48.3)	1.57 (40)	2.01 (51)	0.08 (2)	5 (127)	8	
	400/600	1.00 (25.4)	6.5 (165)	0.75 (19.1)	3.63 (92.1)	1.9 (48.3)	1.57 (40)	2.01 (51)	0.28 (7)	5 (127)	8	
	900/1500	1.5 (38.1)	8.46 (215)	1.00 (25.4)	3.63 (92.1)	1.9 (48.3)	1.57 (40)	2.01 (51)	0.28 (7)	6.5 (165.1)	8	
3 inch	150	0.88 (22.3)	7.48 (190)	0.75 (19.1)	5 (127)	3 (76)	2.65 (65)	3.35 (85)	0.08 (2)	6 (152.4)	4	
	300	1.06 (27)	8.27 (210)	0.87 (22.2)	5 (127)	3 (76)	2.65 (65)	3.35 (85)	0.08 (2)	6.63 (168.3)	8	
	600	1.23 (31.8)	8.27 (210)	0.87 (22.2)	5 (127)	3 (76)	2.65 (65)	3.35 (85)	0.28 (7)	6.63 (168.3)	8	
	1500	1.88 (47.7)	10.43 (265)	1.25 (31.8)	5 (127)	3 (76)	2.65 (65)	3.35 (85)	0.28 (7)	8 (203.2)	8	
4 inch	150	0.88 (22.3)	9.06 (230)	0.75 (19.1)	6.19 (157.2)	3.69 (94)	3.35 (85)	3.35 (85)	0.08 (2)	7.5 (190.5)	8	
	300	1.19 (30.2)	10.04 (255)	0.87 (22.2)	6.19 (157.2)	3.69 (94)	3.35 (85)	3.35 (85)	0.08 (2)	7.87 (200)	8	
	400	1.38 (35)	10.04 (255)	0.87 (22.2)	6.19 (157.2)	3.69 (94)	3.35 (85)	3.35 (85)	0.28 (7)	7.87 (200)	8	
	1500	2.13 (54)	12.20 (310)	1.37 (34.9)	6.19 (157.2)	3.69 (94)	3.35 (85)	3.35 (85)	0.28 (7)	9.5 (241.3)	8	
5 inch	150	0.88 (22.3)	10.04 (255)	0.87 (22.2)	7.31 (185.7)	5 (127)	4.57 (116)	4.57 (116)	0.08 (2)	8.5 (215.9)	8	
	300	1.31 (33.4)	11.02 (280)	0.87 (22.2)	7.31 (185.7)	5 (127)	4.57 (116)	4.57 (116)	0.08 (2)	9.25 (235)	8	
	400	1.50 (38.1)	11.02 (280)	0.87 (22.2)	7.31 (185.7)	5 (127)	4.57 (116)	4.57 (116)	0.28 (7)	9.25 (235)	8	

Pressure Measurement

Transmitters for applications with advanced requirements (Advanced)
SITRANS P320/P420

for level

Process connection according to J.I.S

Nominal diameter	Nominal pressure	b	D	d ₂	d ₄	d ₅	d _M with tube	d _M without tube	f	k	n	L
		mm (inch)	mm (inch)	mm (inch)	mm (inch)	mm (inch)	mm (inch)	mm (inch)	mm (inch)	mm (inch)	mm (inch)	mm (inch)
DN 50	10K	14 (0.55)	155 (6.10)	19 (0.75)	96 (3.78)	48.3 (1.9)	40 (1.57)	51 (2.01)	2	120 (4.72)	4	0, 50, 100, 150 or 200 (0, 2, 3.94, 5.94 or 7.87)
	20K	16 (0.63)	165 (6.50)	19 (0.75)	96 (3.78)	48.3 (1.9)	40 (1.57)	51 (2.01)	2	120 (4.72)	8	
	40K	26 (1.02)	165 (6.50)	19 (0.75)	105 (4.13)	48.3 (1.9)	40 (1.57)	51 (2.01)	2	130 (5.12)	8	
DN 80	10K	16 (0.63)	185 (7.28)	19 (0.75)	126 (4.96)	76 (2.99)	65 (2.56)	85 (3.35)	2	150 (5.91)	8	
	20K	20 (0.79)	200 (7.87)	23 (0.91)	132 (5.20)	76 (2.99)	65 (2.56)	85 (3.35)	2	160 (6.30)	8	
	40K	32 (1.26)	210 (8.27)	23 (0.91)	140 (5.51)	76 (2.99)	65 (2.56)	85 (3.35)	2	170 (6.30)	8	
DN 100	10K	16 (0.63)	210 (8.27)	19 (0.75)	151 (5.94)	94 (3.7)	85 (3.35)	85 (3.35)	2	175 (6.89)	8	
	20K	22 (0.87)	225 (8.86)	23 (0.91)	160 (6.30)	94 (3.7)	85 (3.35)	85 (3.35)	2	185 (7.28)	8	
	40K	36 (1.42)	250 (9.84)	25 (0.98)	165 (6.50)	94 (3.7)	85 (3.35)	85 (3.35)	2	205 (8.07)	8	

d: Internal diameter of seal according to DIN 2690

d_M: Effective diaphragm diameter